

## Installation, Operation and Maintenance Instructions for

# Endurance

- EBP Series** Modulating Combination Boiler  
(natural or propane gas)
- EDP Series** Modulating Hydronic Boiler  
(natural or propane gas)
- EDN Series** Modulating Boiler, non ferrous  
(natural or propane gas)

**FOR YOUR SAFETY:** This product must be installed and serviced by a professional service technician, qualified in hot water boiler installation and maintenance. Improper installation and/or operation could create carbon monoxide gas in flue gases which could cause serious injury, property damage, or death. Improper installation and/or operation will void the warranty.

### **⚠️ WARNING**

If the information in this manual is not followed exactly, a fire or explosion may result causing property damage, personal injury or loss of life.

Do not store or use gasoline or other flammable vapors and liquids in the vicinity of this or any other appliance.

#### **WHAT TO DO IF YOU SMELL GAS**

- Do not try to light any appliance.
- Do not touch any electrical switch; do not use any phone in your building.
- Immediately call your gas supplier from a nearby phone. Follow the gas supplier's instructions.
- If you cannot reach your gas supplier, call the fire department.

Installation and service must be performed by a qualified installer, service agency, or gas supplier.

### **⚠️ AVERTISSEMENT**

Assurez-vous de bien suivre les instructions données dans cette notice pour réduire au minimum le risque d'incendie ou d'explosion ou pour éviter tout dommage matériel, toute blessure ou la mort.

Ne pas entreposer ni utiliser d'essence ni d'autres vapeurs ou liquides inflammables dans le voisinage de cet appareil ou de tout autre appareil.

#### **QUE FAIRE SI VOUS SENTEZ UNE ODEUR DE GAZ:**

- Ne pas tenter d'allumer d'appareils.
- Ne touchez à aucun interrupteur. Ne pas vous servir des téléphones dans le bâtiment où vous vous trouvez.
- Appelez immédiatement votre fournisseur de gaz depuis un voisin. Suivez les instructions du fournisseur.
- Si vous ne pouvez rejoindre le fournisseur de gaz, appelez le service des incendies.

L'installation et l'entretien doivent être assurés par un installateur ou un service d'entretien qualifié ou par le fournisseur de gaz.

## TABLE OF CONTENTS

### SECTION 1.

#### General Information

1A.	Introduction .....	3
1B.	Codes and Standards .....	3
1C.	Unpacking the Appliance .....	4
1D.	Locating the Appliance .....	4
1E.	Clearances .....	4

### SECTION 2.

#### Venting Options

2A.	Direct Vent Kits .....	4
2B.	Installing Direct Vent Kits .....	4
2C.	Locating the Vent on an Outside Wall .....	4
2D.	Stainless Steel Single Pipe Horizontal and Vertical Vents .....	7
2E.	Air Source for Combustion (when not direct vented) .....	7
2F.	Connecting Special Gas Vent to the Appliance .....	8
2G.	Securing Special Gas Vent .....	8

### SECTION 3.

#### Gas Piping

3A.	Gas Piping .....	8
3B.	Domestic Water Piping (EBP only) .....	9

### SECTION 4.

#### Hydronic Heat Piping

4A.	Hydronic Piping .....	10
4B.	Using in a Combined Hot Water Heating and Chilled Water Cooling System .....	12
4C.	Water Quality and Treatment .....	13

### SECTION 5.

#### Electrical Connections

5A.	Electrical Connections .....	13
-----	------------------------------	----

### SECTION 6.

#### Boiler Start-Up

6A.	Common Vent Test .....	17
6B.	Filling the System .....	18
6C.	Firing Burner .....	18
6D.	Mode and On/Off Buttons Operation .....	19

### SECTION 7.

#### Maintenance and Component Description

7A.	Unit Pump .....	19
7B.	Gas Valve .....	19
7C.	Safety Limit Switch .....	19
7D.	Operating Control Printed Circuit Board (PCB) .....	19
7E.	Igniter / Flame Sensor Assembly .....	20
7F.	Transformer .....	20
7G.	Blower .....	20
7H.	Transfer Tank (EBP only) .....	20
7I.	Thermostatic Union (EDP/EDN only) .....	20
7J.	Cleaning the Boiler Coil .....	20

### SECTION 8.

#### Servicing

8A.	Sequence of Operation .....	21
8B.	Trouble Shooting - Fault Codes .....	22
8B-1.	Fault Code Identification .....	22
8B-2.	Fault Correction .....	22
8B-3.	Resolving Lockouts .....	22
	Fault Trees .....	23

### SECTION 9.

#### Gas Valve Calibration

9A.	Gas Valve Calibration .....	31
-----	-----------------------------	----

### SECTION 10.

#### Symptom Evaluations

10A.	Delayed Ignition .....	31
10B.	Short Cycling .....	32
10C.	Noisy Operation .....	32
10D.	Insufficient Hot Water (EBP only) .....	32
10E.	High Gas Consumption .....	33

### SECTION 11.

	Parts Identification .....	34
--	----------------------------	----

## SECTION 1. General Information

### 1A. Introduction

**EBP** - This appliance is a low pressure, direct vent, hot water boiler that provides priority domestic hot water on demand as well as hydronic space heating system. The unit has a twenty gallon tank which holds boiler water (and is not domestic water storage).

The boiler water is kept hot at all times to provide immediate response to call for heat or domestic water. Domestic water is heated by the boiler water through a stainless steel plate heat exchanger.

**EDP/EDN** - This appliance is a low pressure, direct vent, cold start hot water boiler that provides heat for hydronic space heating.

Both appliances incorporate a circulating pump and a bypass loop, and provide circulation for the heating system and adequate flow for its own needs. It may be necessary to install a system circulator to achieve the required flow rate through the system.

Both appliances feature a forced draft, premixed combustion system. All air for combustion is supplied with the gas to the burner (flame holder). Both the

intake air and the gas are metered through separate orifices before entering the combustion air blower. The blower forces the air/fuel mixture through the flame holder and into the combustion chamber. The mixture is ignited from the hot surface ignitor and burns. Hot gases are forced out between the passes of the heat exchanger into the flue collector. Flue gases are discharged into the outside atmosphere through the vent terminal.

The appliance can operate with a concentric vent system that will provide outside air for combustion. Other venting arrangements can be provided for the appliance to include an alternative 50 equivalent feet maximum horizontal or condensate trapped vertical vent.

### 1B. Codes and Standards

The Endurance may be a direct vent or Category IV Boiler. All installations must be made in accordance with:

1. The National Fuel Gas Code, ANSI Z223.1 latest edition, or.
2. CAN/CGA B149 "Installation Codes for Gas Burning appliances and Equipment" and with the requirements of the local utility or other authorities having jurisdiction. Such application requirements take precedence over the general instructions contained herein.

All electrical wiring is to be done in accordance with:

1. The National Electrical Code ANSI / NFPA70 latest edition or

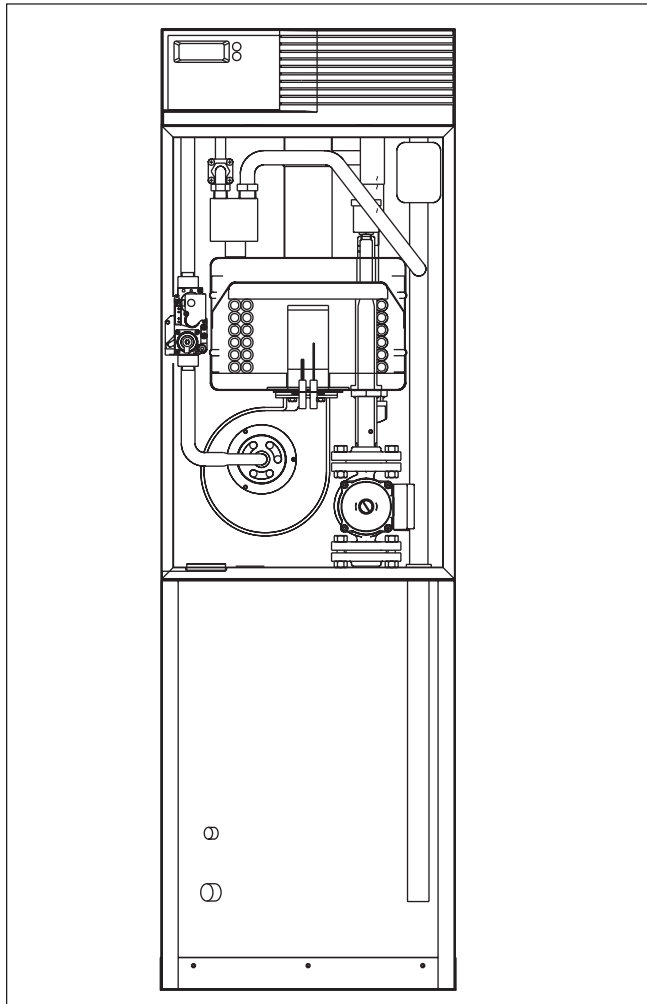

Figure 1. Combo Heating/Domestic Water (Model EBP).

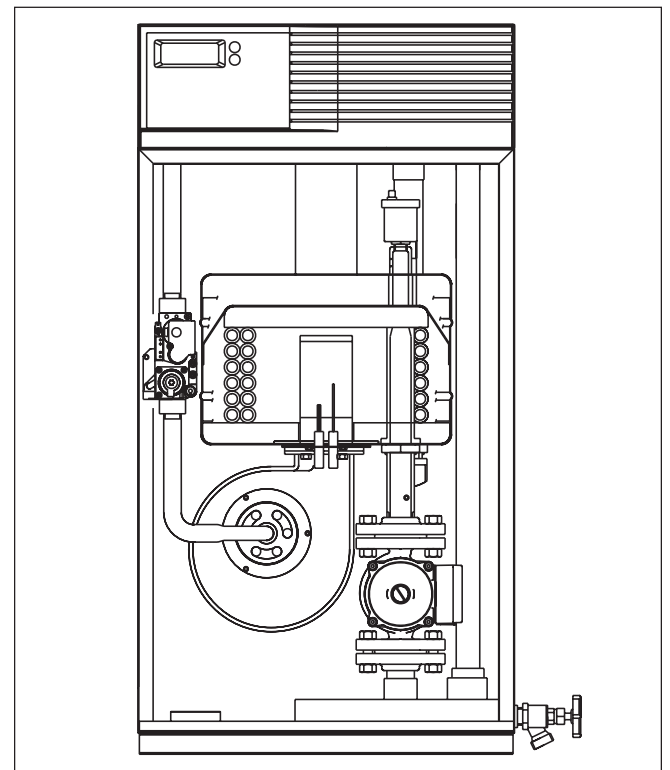

Figure 2. Heating Unit (Model EDP/EDN).

- The CSA standard C22.1 “Canadian Electrical Code - Part 1” and local codes.

All vent installations must be made in accordance with:

- Part 7, Venting of Equipment of the National Fuel Gas Code, ANSI 223.1 latest edition, or applicable provisions of the local building codes or
- CAN/CGA B149.

When required by the jurisdiction authority, the installations must conform to the American Society of Mechanical Engineers' Safety Code for Controls and Safety Devices for Automatically Fired Boilers, No. CSD-1.

### 1C. Unpacking the Appliance

Remove all packing and tie down materials. Make immediate claims (to the carrier) if the appliance and its packaging are damaged.

### 1D. Locating the Appliance

The appliance is designed for installation on combustible flooring, in alcoves, basements, closets, or utility rooms. It must not be installed on carpeting. **IF INSTALLED IN A FINISHED AREA, PROVISION SHOULD BE MADE FOR DRAINAGE OF ANY ACCIDENTAL SPILLAGE OR LEAKAGE.**

The location for the unit should be chosen with regard to venting dimensions, convenient access to piping, and accessibility for service and cleaning.

The boiler shall be installed so that the gas ignition system components are protected from water (dripping, spraying, rain, etc.) during appliance operation or service (circulator replacement, control replacement, etc.).

### 1E. Clearances

The dimension and criteria in Table 1 should be followed when choosing the location for the unit.

	A		B			
	AGA/CGA		AGA		CGA	
	in.	mm	in.	mm	in.	mm
Left Side	1	25	6	152	24	610
Right Side	1	25	12	305	24	610
Top Side	1	25	14	356	24	406
Back	1	25	9	229	12	305
Front	1	25	24	610	24	610
Vent: Direct Vent	0	0	0	0		
Vent: Category IV	3	76	3	76		

- Minimum clearance from combustible construction to meet AGA/CGA requirements.
- Recommended clearance for accessibility and venting.

**Table 1. Clearances**

## SECTION 2. Venting Options

### 2A. Direct Vent Kits

When using a direct vent kit, the appliance is a sealed combustion unit. All of its air is drawn in from the outside through the 5" outer pipe. Flue gases are vented through the 3" vent pipe positioned inside the 5" intake pipe. The hot flue gases are surrounded by the intake flow of cooler outdoor air. This vent system may be installed through, and be in contact with, combustible materials. Except for roof vent kit (max 7' vertical) all venting should pitch away (down) from unit.

### 2B. Installing Direct Vent Kits

The direct vent appliance is certified with a maximum of 15 linear feet (4.6m) of vent pipe and three sets of elbows. There are two basic vent kits available, together with various additional elbow and extension kits if required (see Figures 3 and 4). Detailed installation instructions are provided in the kits.

For additional length and/or fittings, the following components are available:

3" and 5" elbow set	Part Number 2400-330
5" x 1' extensions	Part Number 2400-332
5" x 2' extensions	Part Number 2400-334
5" x 2' to 4' adjustable extensions	Part Number 2400-336
3" x 1' extensions	Part Number 2400-338
3" x 2' extensions	Part Number 2400-340
3" x 2' to 4' adjustable extensions	Part Number 2400-342

### 2C. Locating the Vent on an Outside Wall

The center line of the vent opening must be at least 16½" (419mm) above grade, outside, and at least 13½" (343mm) from any other building opening, such as doors, windows, etc. Vent opening should be well away from shrubbery or other obstructions that would prevent free air flow to and from vent terminal. Do not terminate vent under decks, stairways, or car ports.

**NOTE:** Should it be impossible to locate opening center line 16½" (419mm) above grade, use optional vent terminal extension (p/n 2400-278).

Vent terminals must also be at least 3' (0.9m) above any forced air inlet located within 10' (3.0m), and at least 7' (2.1m) above grade when located adjacent to a public walkway, and cannot terminate in a location where condensate or vapor may be a nuisance, hazard, or could be a detriment to other equipment. Vent terminals must have a minimum clearance of 4' (1.2m) (6' (1.8m) in Canada) horizontally from, and in no case above or below electrical meters, gas meters, regulators, and relief equipment unless a 4' (1.2m) horizontal distance is maintained.

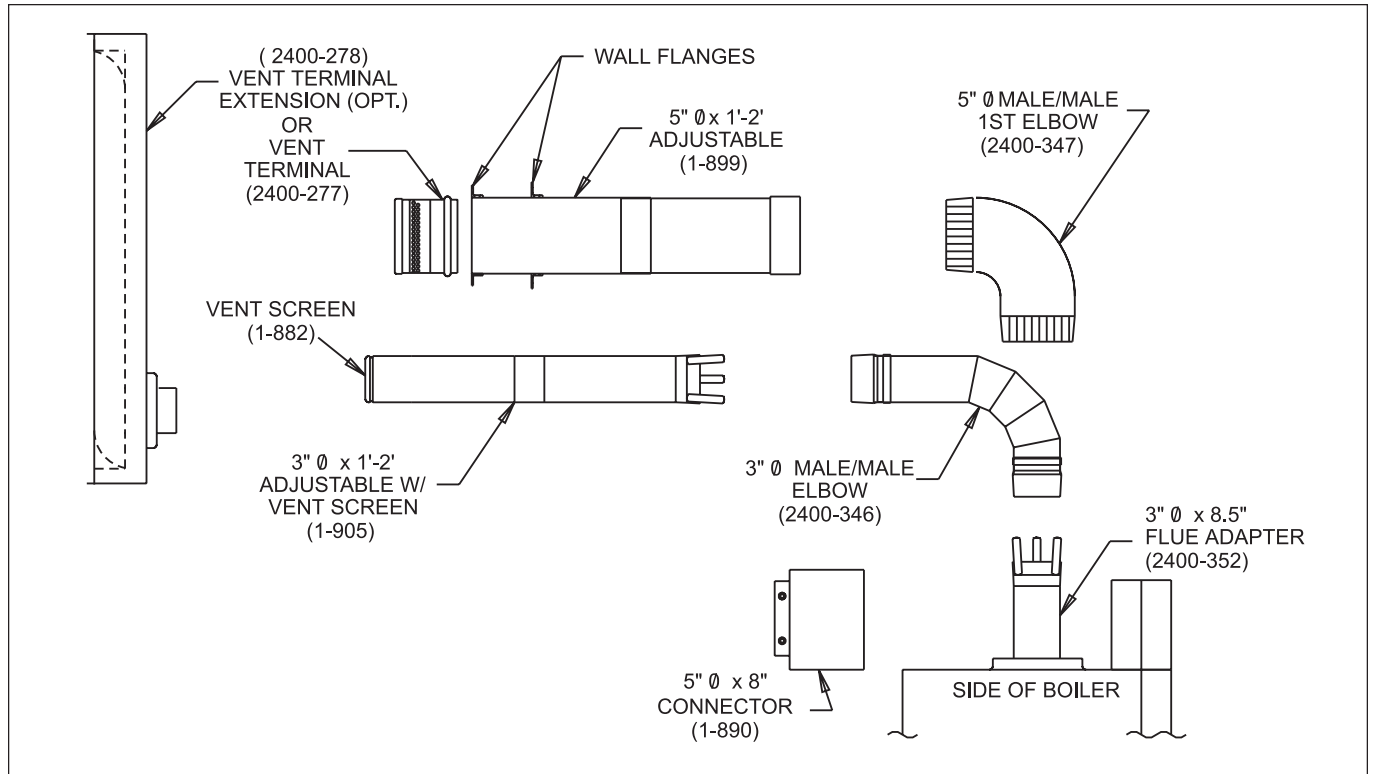

**Figure 3. Part number 2400-500 provides all of the required venting materials for appliance installations adjacent to an outside wall and for installation of wall mounted units. Requires minimum above unit clearance of 13" (330mm) and provides maximum horizontal length of 24" from unit center line to outside wall face.**

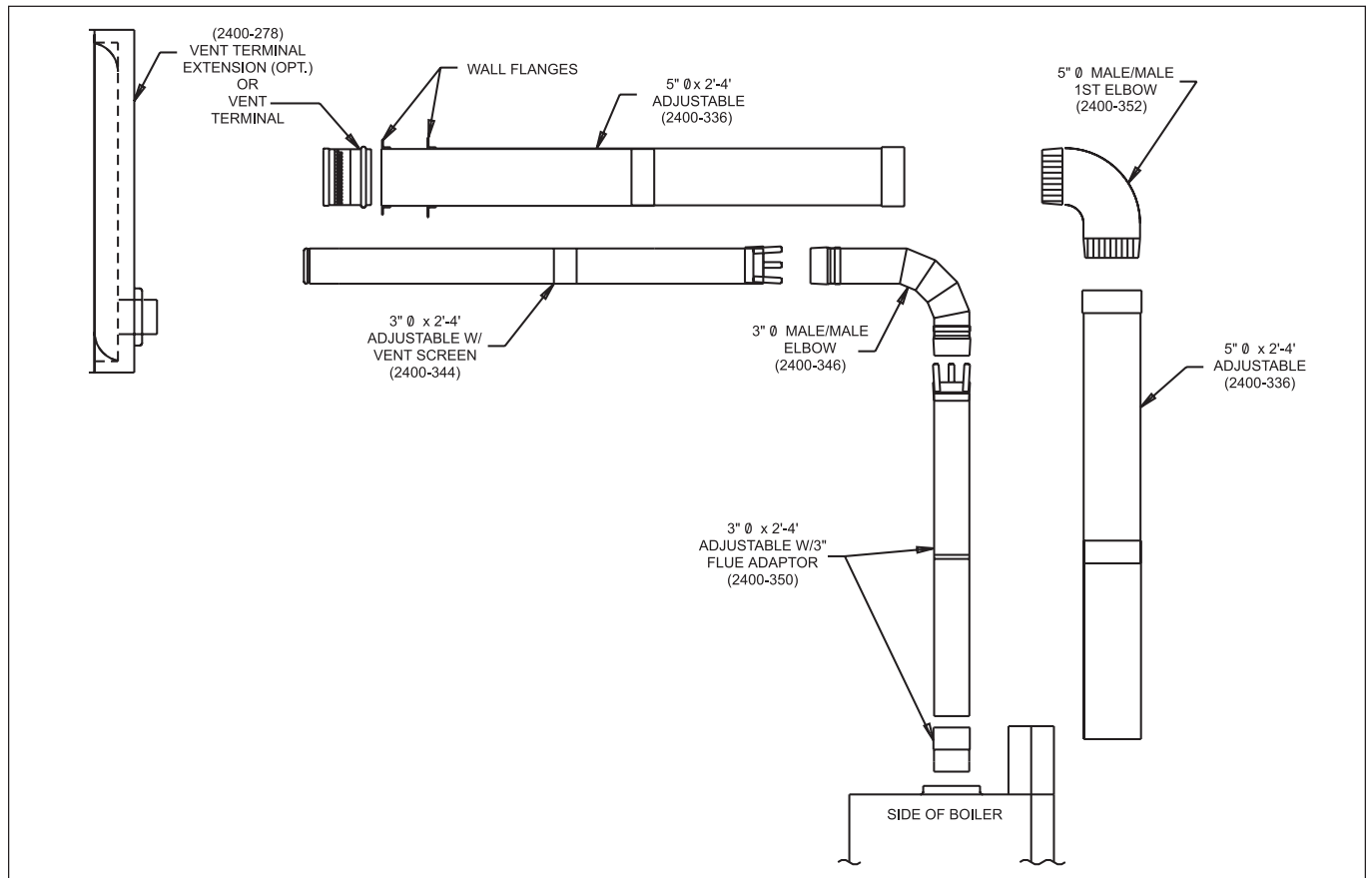

**Figure 4. Part number 2400-326 for vent installations which require adjustable height and horizontal run. This kit provides vertical and horizontal lengths of pipe from 2' to 3½' (0.6 to 1.1m). To adapt 2400-278 (vent terminal extension) remove 3" screen section of telescoping piece. Companion section will directly fit extension.**

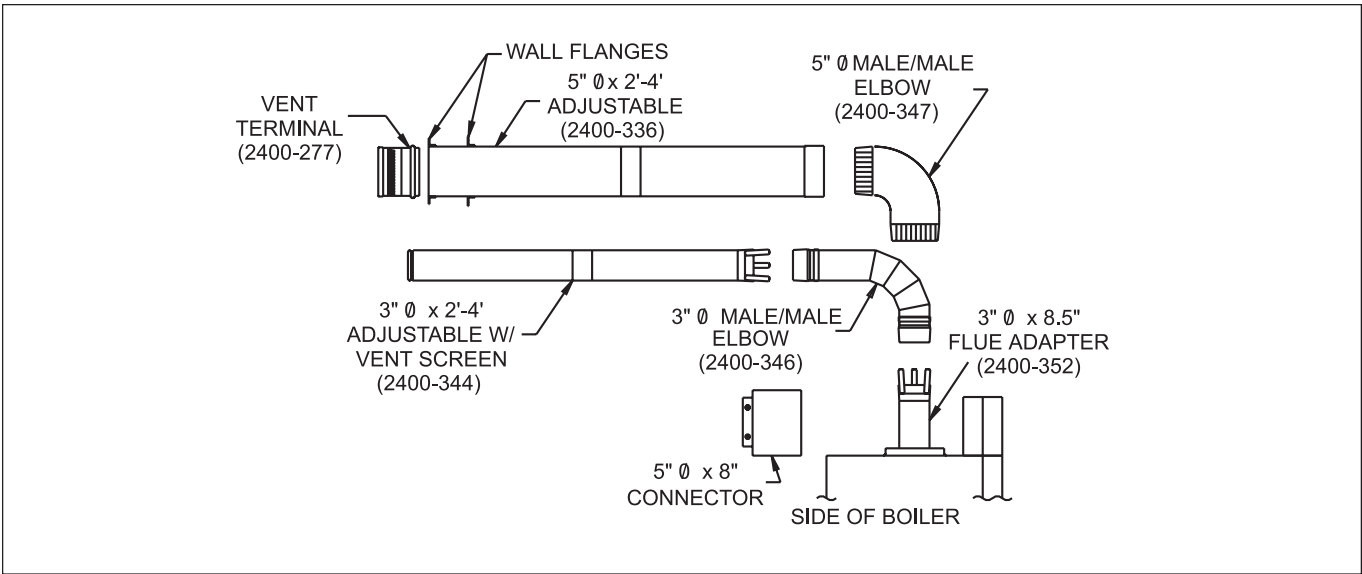

Figure 5. Part number 2400-328 provides all of the required venting materials for appliance installations that require adjustable horizontal run, but a short vertical run. It requires minimum above unit clearance of 13" (330mm) and provides for an adjustable horizontal run of 2' to 3-1/2' (0.6 to 1.1m).

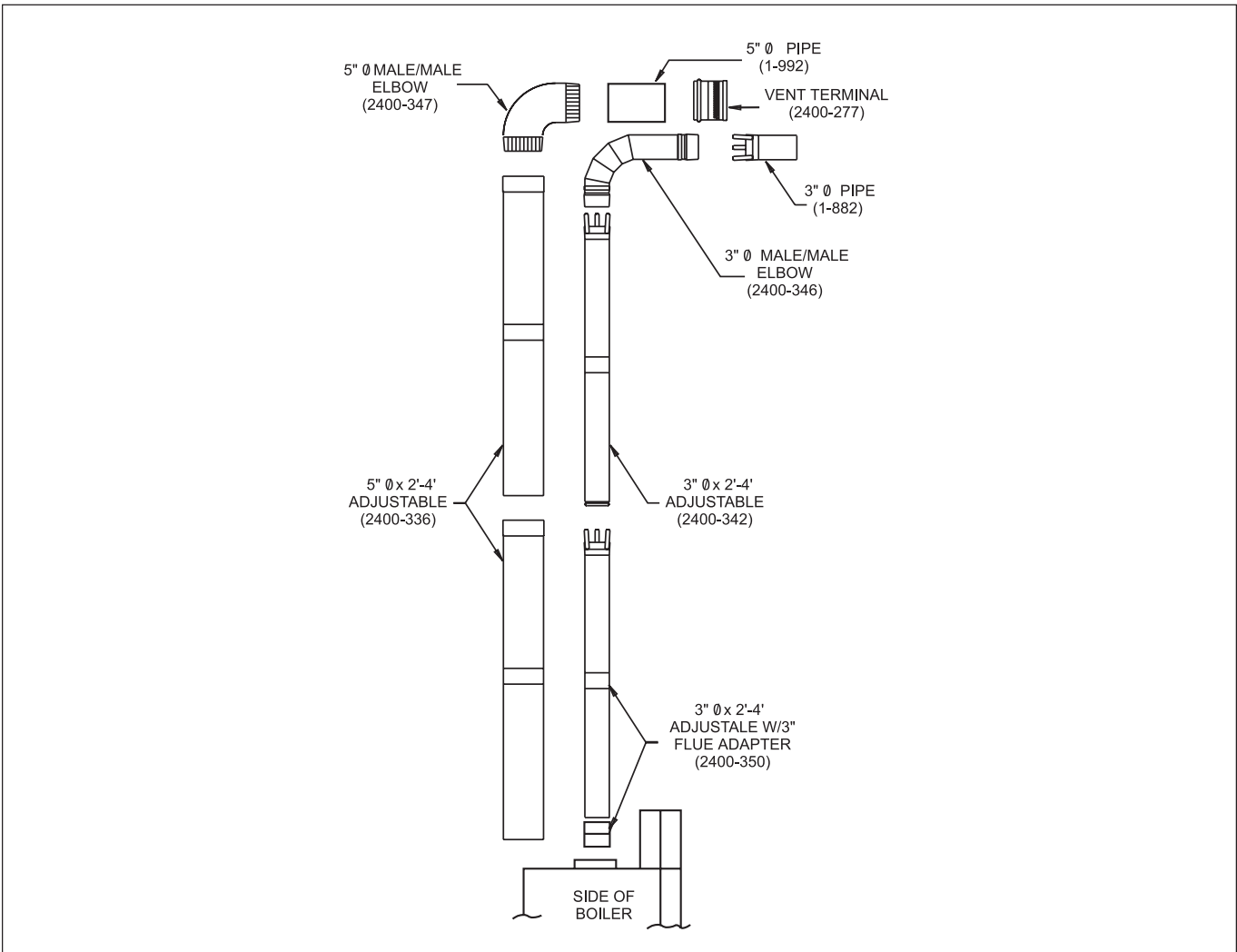

Figure 6. Part number 2400-360 provides the required venting materials for concentric through-the-roof vents. It allows for a vertical vent, straight off the top of the unit, from 2 to 7 feet (0.6 to 2.1m).

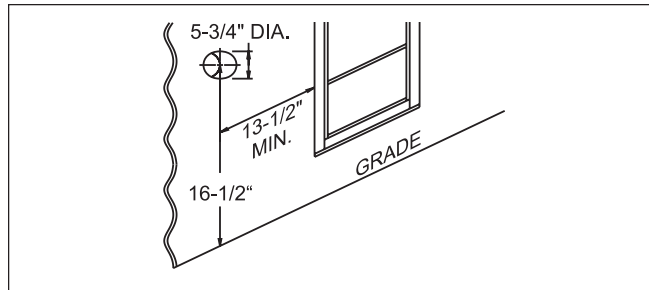

Figure 7. For Appliances Certified as Direct Vent.

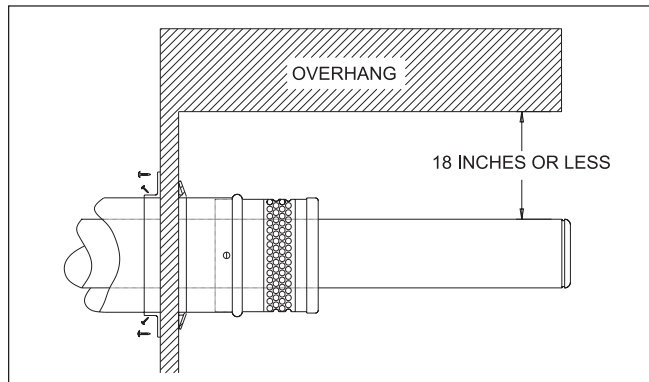

Figure 8. Typical vent installation with 18" or less overhead clearance to outside.

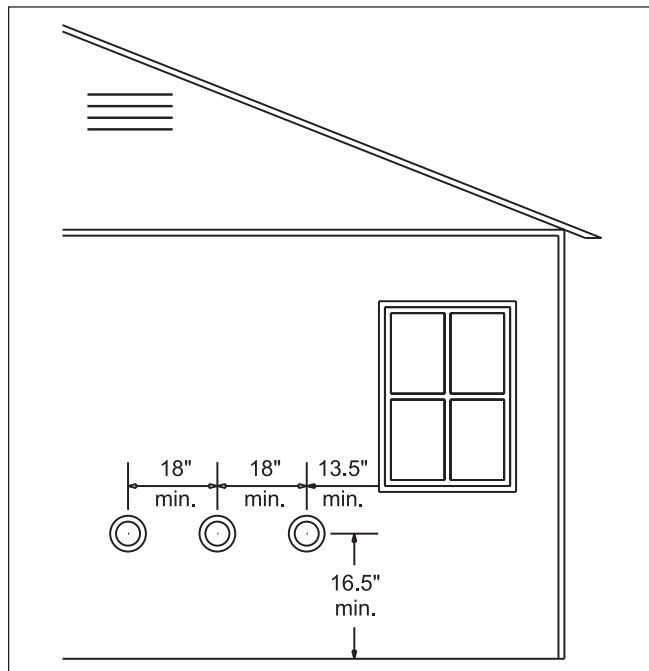

Figure 9. Multiple Concentric Vent Clearances.

When appliances are used, the concentric vent terminals must be at least 12" apart, edge-to-edge (see Figure "term").

Do not locate the vent terminal where blockage by snow is a possibility, or where flue products could strike against building materials and cause degradation. If the vent terminal location chosen is less than 18" below an overhang, the 3" vent pipe must extend to the outside edge of the overhang (see Figure 6).

## 2D. Stainless Steel Single Pipe Horizontal and Vertical Vents - Category IV

Stainless steel special gas Vent listed to U.L. Standard 1738 and U.L.C. Standard 636 may be used

Minimum clearance from combustibles (vent)	3"	76mm
Max. flue gas temp.	325°F	163°C
Max. vent pressure	1.5" WC	0.4kPa
Max. equivalent ft. of venting (any combination of horizontal or vertical)	3" diameter 50 equiv. ft.	76mm diameter 15.2m
Max. equivalent ft. of venting (any combination of horizontal or vertical)	100 equiv. ft. 4" diameter	30.5m 102mm dia.

Table 2. Appliance Venting Design Data.

to vent all models. Vent pipe and fittings are manufactured to these standards by HeatFab, Inc. under the trade name of Saf-T Vent® and by Z-Flex™ under the trade name of Z-Vent. Follow the Special Gas Vent manufacturer's instructions regarding design, location and assembly of the vent system.

The appliance may be vented with any number of elbows or fittings provided that the maximum equivalent feet of venting is not exceeded. Elbows (90°) in the vent system shall be considered to be 5 equivalent feet (1.5m). When vented with special gas vent, the appliance must not be common vented with any other appliance.

For applications requiring vertical venting through a roof, the above limitations apply. Vertical vents greater than 7' (2.1m) in length must offset a condensate trap tee p/n 2400-358 adjacent to the appliance. Utilize vent cap p/n 2400-370 to terminate vertical venting.

## 2E. Air Source For Combustion (when not direct vented)

When using Category IV venting methods the appliance draws all combustion air through its top and from the adjacent space. When locating the appliance in unconfined spaces in buildings, infiltration may be adequate to provide air for combustion and ventilation. However, in buildings of unusually tight construction, or when locating the appliance in a confined space, additional air should be provided and the following guidelines must be followed.

1. If the space is in a building of unusually tight construction, air should be obtained from outdoors, or from spaces which freely connect with outdoors.
2. For boilers in confined rooms, two permanent openings shall be provided - one within 12" (305mm) of the ceiling, and one within 12" (305mm) of the floor of each room. Each opening shall be at least one square inch

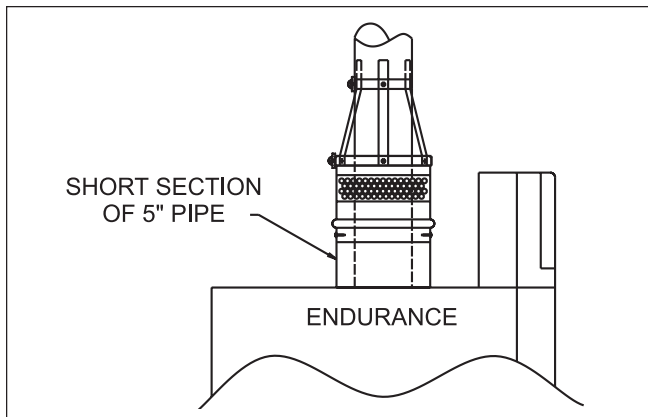

Figure 10. Special Gas Vent Connection.

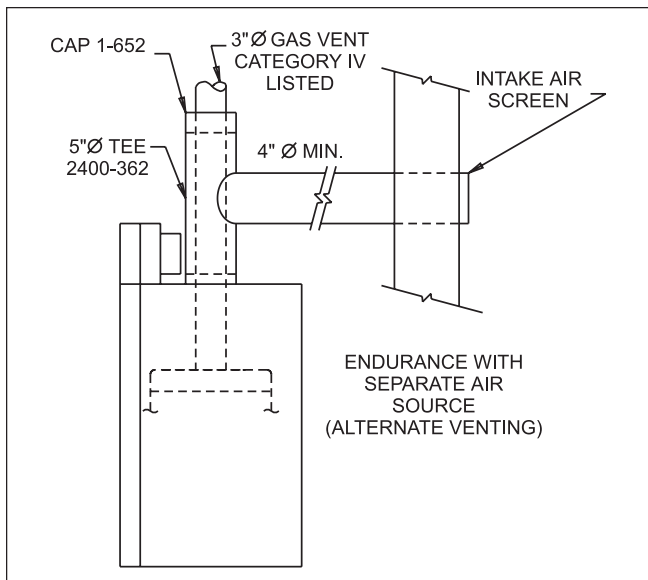

Figure 11. Non-Concentric Combustion Air Source.

(6.5 sq. cm) per 1,000 BTU/hr (293W) boiler input, but not be less than 100 square inches (645.2 sq. cm). These openings shall freely connect with areas having adequate infiltration from outside.

3. When all air is provided from outdoors, the confined space shall be provided with one opening within 12" of the ceiling. This opening shall connect directly, or by ducts, with outdoors or spaces (crawl or attic) that freely connect with the outdoors, and shall have a minimum free area of:
  - a. 1 sq. in. per 3000 BTU/hr (7 cm<sup>2</sup>/kw) of the total input rating of all equipment located in the enclosure, and
  - b. Not less than the sum of the areas of all vent connectors in the confined space.

## 2F. Connecting Special Gas Vent to the Appliance

Part number 2400-372 is used with a vent terminal (p/n 2400-277) to secure the 3 inch special

gas vent to the flue outlet of the appliance. Heat-Fab pipe or fittings (p/n 2400-350 or 2400-352) or the male end of Z-Vent pipe (Z-Vent # 02 SVEPXX030) may be installed over the flue outlet of the Appliance (see Figure 10).

## 2G. Securing Special Gas Vent

Attach p/n 2400-277 with sheet metal screws to the 5" collar on the appliance with a short piece of 5" pipe or to the end of the 5" combustion air duct. Attach p/n 2400-372 bracket and tighten clamp. Form the tabs on the bracket onto the special gas vent pipe and secure the tabs with the 3" clamp. After the clamp has been tightened, fold the end of the tabs down over the clamp (see Figure 10).

DO NOT use screws in any portion of the 3" special gas vent.

When providing combustion air from another location, the connection of the 5" duct to the appliance must be secured with sheet metal screws.

Each 5" joint in the 5" duct must be secured with sheet metal screws.

In this type of installation, p/n 2400-372 must be used to secure the special gas vent at the point where it exits the duct. The combustion air supply should be protected from debris entering the duct with an appliance vent terminal, p/n 2400-277, as shown in Figure 8 or with a large mesh screen.

Follow the special gas vent manufacturer's instructions for cleaning and sealing all parts before assembling.

Apply ¼" bead of silicone sealer (GE108 or Novagard 400) to the 3" flue outlet of the appliance approximately 1" from the end.

Slide 3" inner vent pipe or 1-880 adapter, when using outer 3" telescoping section, over the appliance flue outlet and push down to stop (do not force pipe beyond stop).

Apply another bead of silicone around this joint and smooth out.

Apply ¼" bead of silicone to subsequent 3" joints.

An alternate, nonconcentric combustion air source may be installed (as shown in Figure 11), provided that the minimum 4" diameter combustion air duct does not exceed 15' (4.6m). Termination should include an air screen and be located in a qualified air space (see Section 2E) or outside.

## SECTION 3.

### 3A. Gas Piping

The appliance requires an inlet gas pressure of at least 4" w.c. (1.0kPa) and no greater than 13" WC (3.2kPa). Check with your local gas utility or supplier for availability of this pressure range.

Refer to Table 3 to size the supply piping to minimize pressure drop between meter or regulator and unit.



Length of Pipe		Capacity of Pipe							
		1/2"		3/4"		1"		1-1/4"	
ft.	m	MBTU/h	kW	MBTU/h	kW	MBTU/h	kW	MBTU/h	kW
10	3	132	38.7	278	81.5	520	152.4	1050	307.7
20	6.1	92	27	190	55.7	350	102.6	730	213.9
30	9.1	73	21.4	152	44.5	285	83.5	590	172.9
40	12.2	63	18.5	130	38.1	245	71.8	500	146.5
50	15.2			115	33.7	215	63	440	128.9
75	22.9			93	27.2	175	51.3	360	105.5
100	30.5			79	23.1	150	44	305	89.4
150	45.7			64	18.8	120	35.2	250	73.3
Additional length to be added for each tee or bend									
		ft	m	ft	m	ft	m	ft	m
		1.3	0.4	1.7	0.5	2.2	0.7	2.7	0.8

Table 3.

1. Run gas supply line in accordance with all applicable codes.
2. Locate and install manual shutoff valves in accordance with state and local requirements.
3. Install drip leg, ground joint union and drip cap to trap sediment and for test gauge access.
4. Support all piping with proper hangers.
5. All threaded joints should be coated with piping compound resistant to the action of liquefied petroleum gas.
6. The boiler and its individual shutoff valve must be disconnected from the gas supply piping system during any pressure testing of that system at test pressures in excess of 1/2 psig (3.5kPa).
7. The boiler must be isolated from the gas supply piping system by closing its individual manual shutoff valve during any pressure testing of the gas supply piping system at test pressures equal to or less than 1/2 psig (3.5kPa)
8. The boiler and its gas connection must be leak tested before placing the boiler in operation.
9. Purge all air from gas lines.

2. Connect gate or shutoff valve (13) to tempering (mixing) valve (12) "MIX" port, and cold water inlet.
3. Install supplied flow restrictor (14) ahead of tempering (mixing) valve tee.
4. Connect pressure relief valve (1) (if required by codes), maximum 150 PSI as close to the unit as possible. No other valves or restrictions may be installed between the Endurance and the relief valve.

DO NOT USE A TEMPERATURE/PRESSURE RELIEF VALVE AS THIS IS NOT A STORAGE HOT WATER HEATER.

**Note: Installations with water containing 10 or more grains of hardness, must be installed with appropriate water treatment.**

### 3B. Domestic Water Piping (EBP only)

1. Connect tempering (mixing) valve (12) "Hot" port to hot water outlet from unit. This valve should

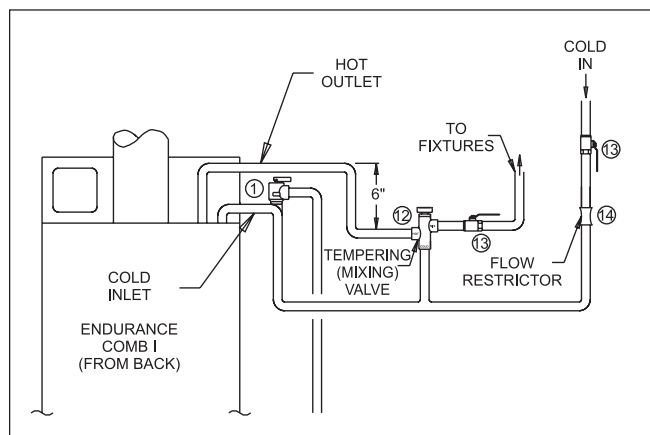

Figure 12. Domestic Water Piping.

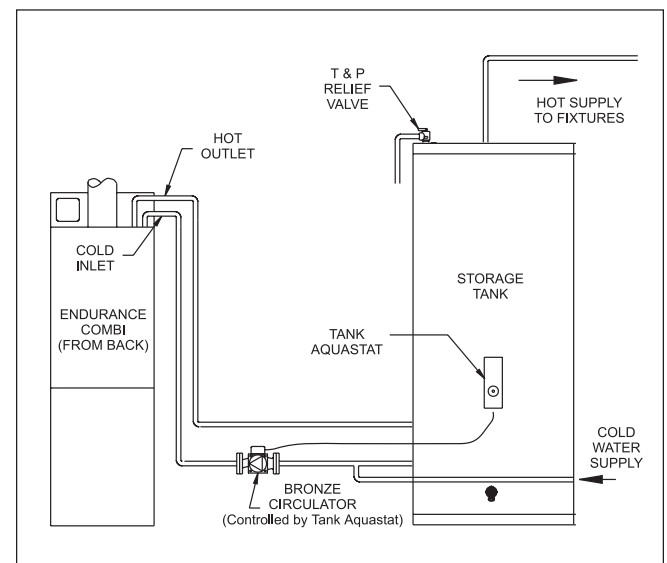

Figure 13. Domestic Water Piping With Storage Tank.

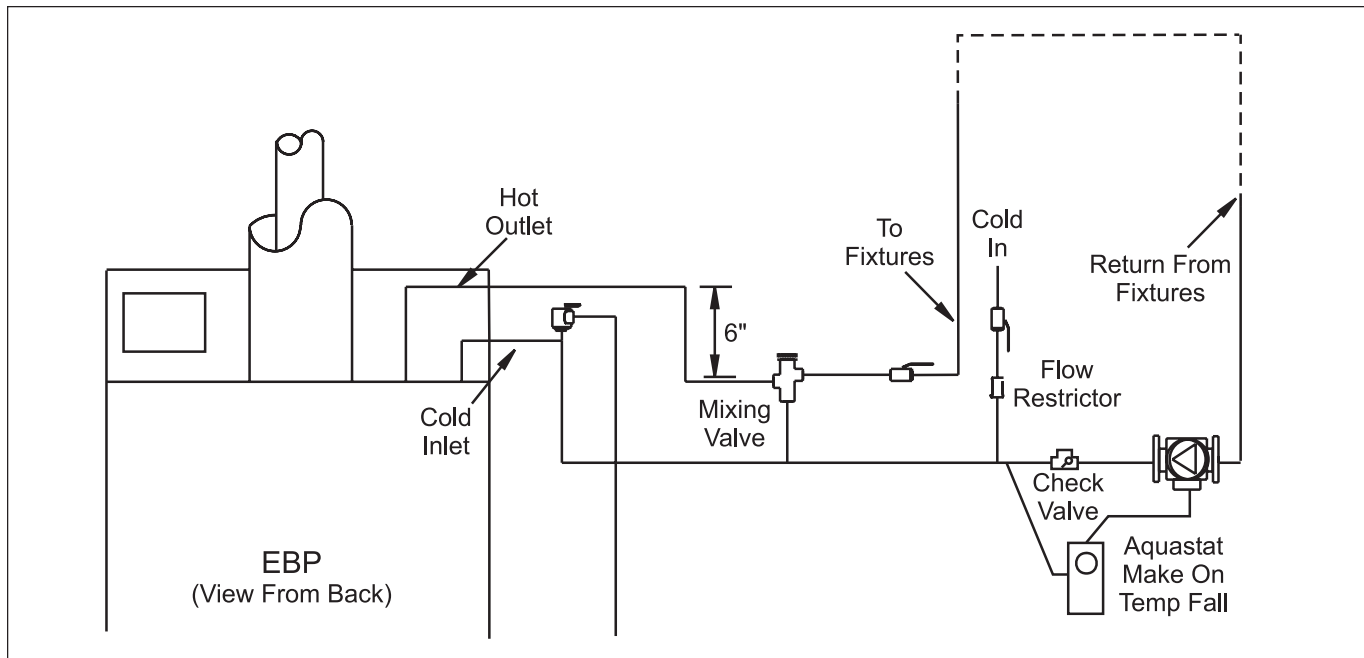

Figure 14. EBP Domestic Water Piping with Recirculating Loop.

### **⚠ WARNING**

Failure to install a hot water tempering (mixing) valve (12) creates a scalding hazard with potential for serious bodily injury. Some brands of tempering (mixing) valves are not designed as anti-scald valves.

Where domestic water is supplying multiple apartments or large whirlpool tubs, additional storage tank may be connected as shown in Figure 13. The bronze circulator shown must be connected to tank aquastat and must not run continuously. If the circulator is wired to run continuously, unit's domestic water flow switch will keep the unit in domestic water priority, and no water will be allowed to be sent to the heating system.

## SECTION 4. Hydronic Heat Piping

### 4A. Hydronic Piping

The appliance incorporates its own circulating pump and bypass loop and is capable of providing flow through heating zones, in addition to what it needs for itself. Model size 110 is capable of providing flow for two heating zones (up to 67 feet of  $\frac{3}{4}$ " baseboard each), and model 175 is capable of providing flow for four heating zones (up to 67 feet of  $\frac{3}{4}$ " baseboard, each).

EDP/EDN boilers installed in radiant (in floor) systems and other low mass boilers should be provided with a buffer/blender tank to assure a controlled supply temperature, and to prevent short cycling. In radiant systems utilizing 3-way tempering valves, a

bypass pipe must be installed between supply and return piping.

1. EBP ONLY: Connect system supply to  $1\frac{1}{4}$ " supply connection marked "SUPPLY".
2. EDP/EDN ONLY: Connect  $1\frac{1}{4}$ " thermostatic union to system supply connection in direction designated with union.
3. Pipe the discharge of the relief valve, full size, to a drain or in a manner to prevent injury in the event of pressure relief.
4. Install an air purger in flow supply line as shown in Figures 15, 16 or 17.
5. Install automatic float type air vent on air scoops.
6. Install a diaphragm expansion tank in boiler outlet piping. To ensure sufficient expansion volume for the hydronic system water, due to heat-up and cool-down during normal operation, a #30 or larger expansion tank must be used on EBP combo units.  
**NOTE: Never install expansion tank and auto fill valve on return.**
7. If necessary, install a properly sized circulator with optional isolation valves in supply beyond expansion tank.

### **⚠ Caution**

All hot water pipes must be installed with a minimum 1" (25mm) clearance from combustible materials.

8. Connect boiler feed water supply with shut off valve to inlet connection of automatic fill valve. Locate in boiler outlet piping.
9. If codes require, install suitable back flow preventer between automatic fill valve and city main.
10. The appliance may be installed in single and multiple zone systems (using either zone valves

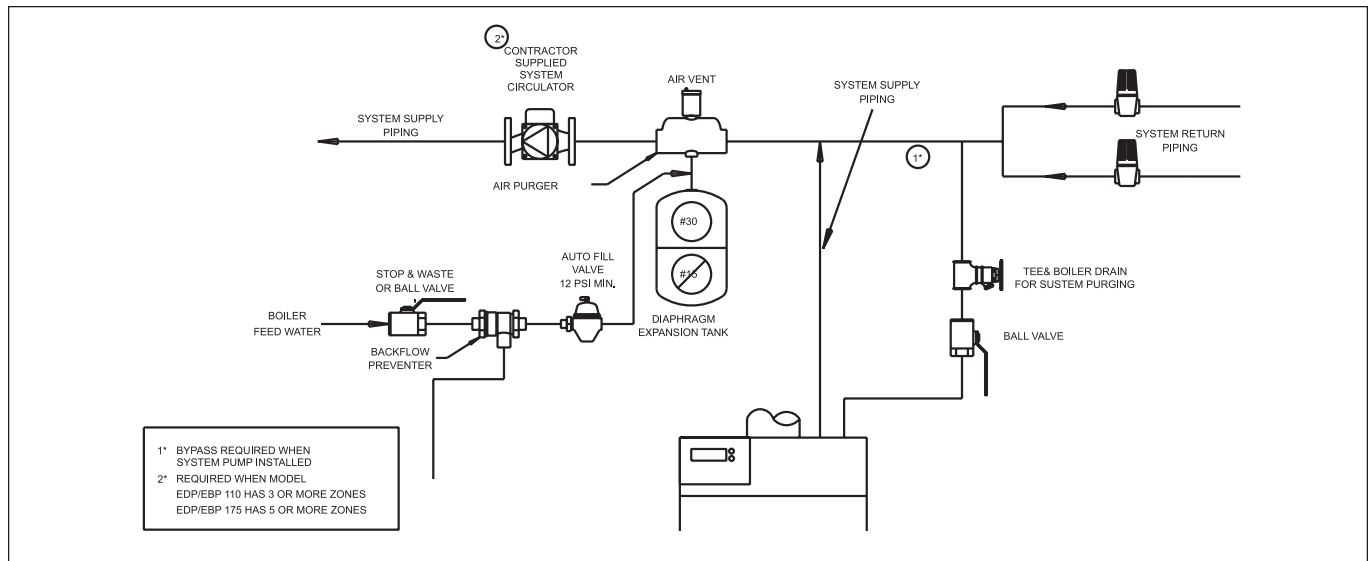

Figure 15. Hydronic Piping EDP/EBP with Zone Valves.

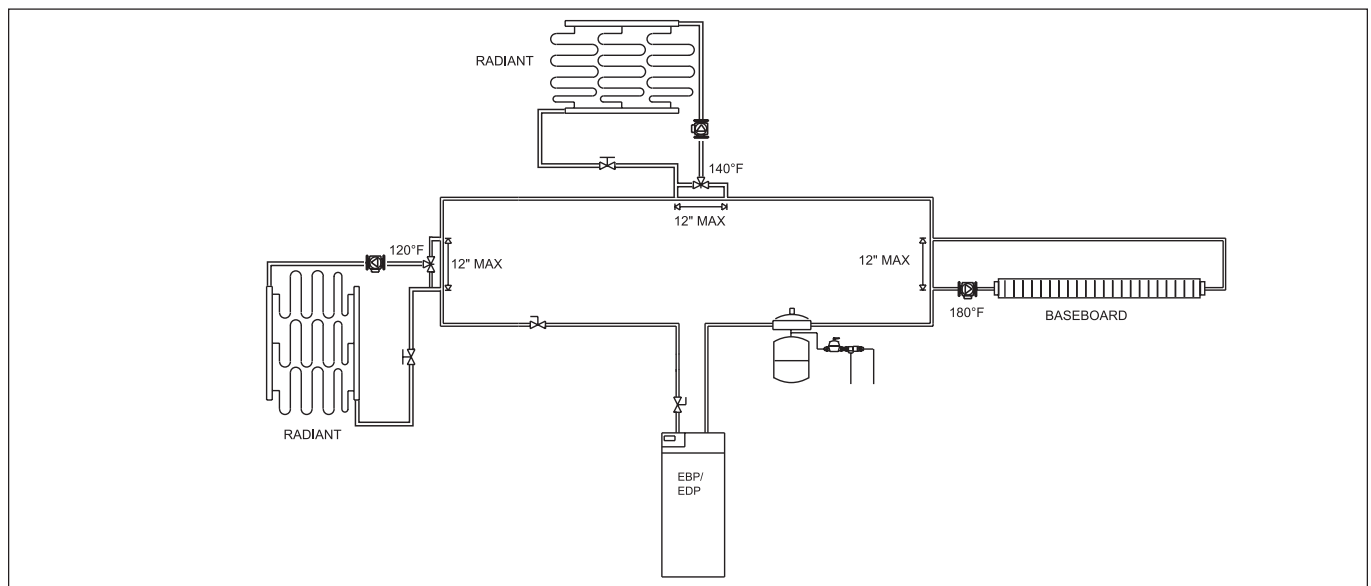

Figure 16. Piping, Single EDP/EBP Boiler for Multiple Temperature Systems.

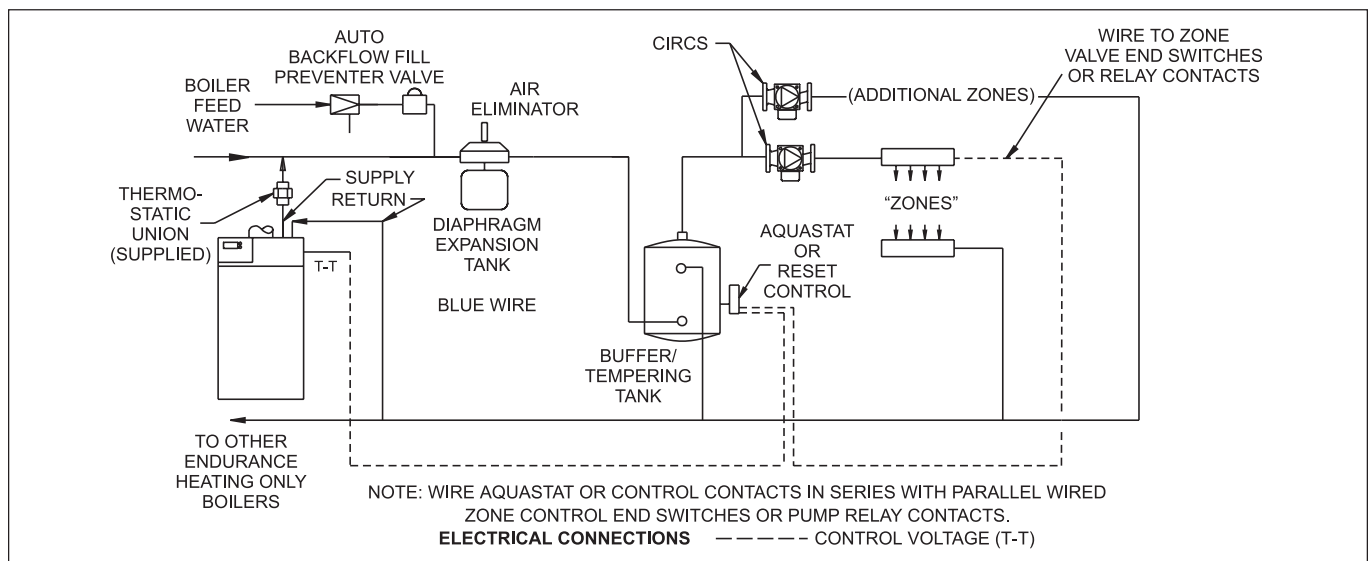

Figure 17. Piping, Model "EDP/EDN" for Radiant Floor.

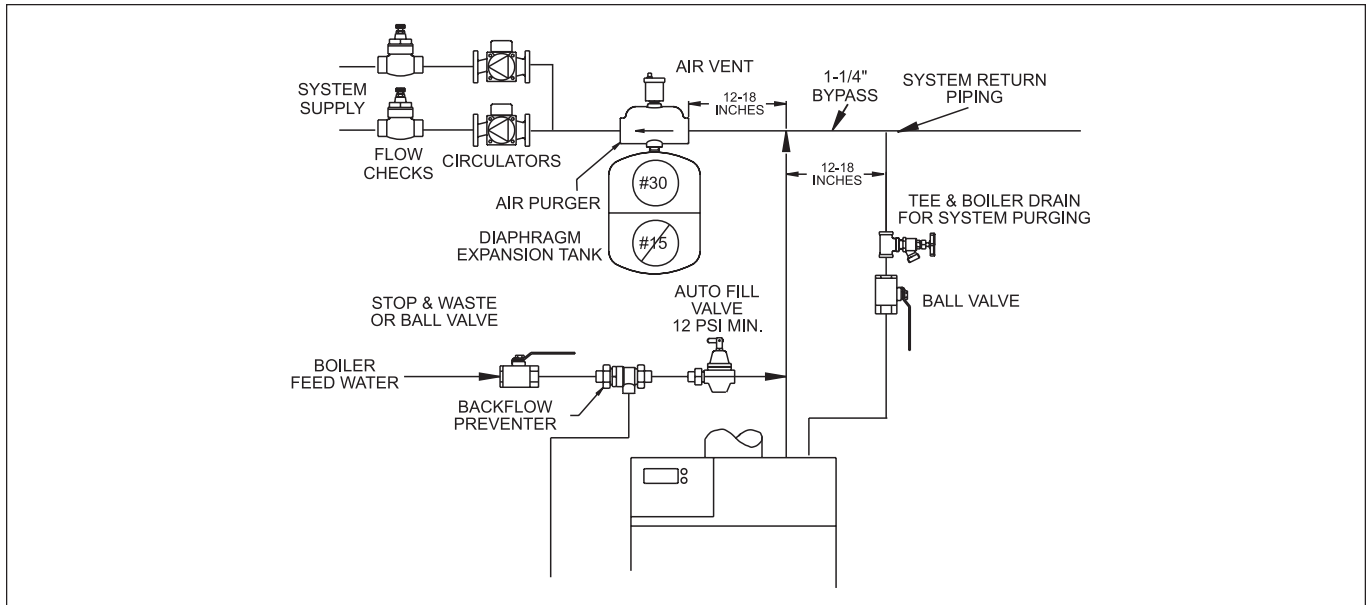

Figure 18. Hydronic Piping EBP/EDP for Systems Zoned with Circulators.

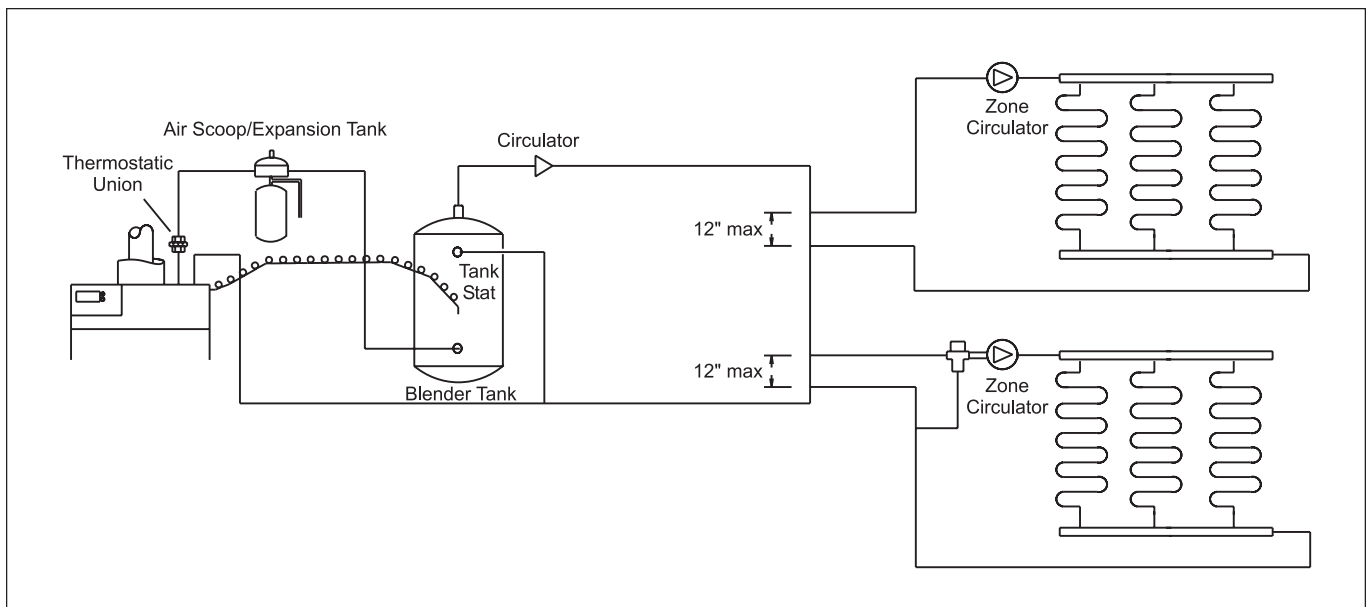

Figure 19. Hydronic Piping EDP for Low-Temp and/or Multi-Temp Systems.

or zone circulators) in the same manner as any other residential boiler.

**Caution**

The EBP/EDP appliance must not be direct connected to a heating system utilizing oxygen permeable tubing (see warranty). Provide a water to water heat exchanger between systems to prevent corrosion of tank or other components. Non-toxic heating system antifreeze may be added to the hydronic system provided that the concentration does not exceed 35% and the antifreeze contains an anti foamant.

**4B. Use in a Combined Hot Water Heating and Chilled Water Cooling System**

When the appliance is used in connection with a refrigeration system, it must be installed so that the chilled medium is piped in parallel with the boiler with appropriate valves to prevent the chilled medium from entering it.

The boiler piping system of an appliance connected to heating coils located in air handling units where they may be exposed to refrigerated air circulation must be equipped with flow control valves or other automatic means to prevent gravity circulation of the boiler water during the cooling cycle.

### 4C. Water Quality and Treatment

Water quality control is steadily increasing in importance in view of the use of modern regulation technology and the modern boiler designs used in central heating systems.

The life of a central heating boiler can be severely curtailed as a result of the formation of scale deposits and/or corrosion products. The formation of such deposits should be prevented wherever possible.

Continual water make-up is not permitted.

A suitable water treatment should be used to prevent excessive scale deposits in the boiler and corrosion in the system.

## SECTION 5. Electrical Connections

All electrical wiring must conform to local codes and/or the National Electric Code or Canadian Electrical Code, Part 1.

The unit must be electrically grounded in accordance with the requirements of the authority having jurisdiction or, in the absence of such requirement, with the National Electrical Code, ANS/NFPA No. 70 latest edition, or the CSA Standard C22.1 "Canadian Electrical Code, Part 1."

Single pole switches, including those of safety control and protective devices must not be wired in a grounded line.

All electrical connections are made in the field wiring box which is located on the top of the appliance, behind the right hand side of the control pod.

**NOTE:** All internal electric components have been pre-wired. No attempt should be made to connect electric wires to any other location except the wiring box as described below.

1. Main power: Connect a fused 120 volt supply (15 amp) to the main power switch (see Figure 20) (hot leg is connected directly to switch). Neutral leg to white wire. Ground wire can be connected to the grounding screw in the box or on the switch.

2. For single zone installations: (If external pump is required, e.g., because of large system pressure drop) connect room thermostat wires to the red and white/red wires. Connect circulator (120 volt, 5 amps maximum) between the blue wire and the white wire (neutral) (see Figure 21).
3. Zone Valves and Thermostats: Install external 24 volt transformer of sufficient V.A. to power combined load of zone valves. Consult zone valve manufacturer's instructions. Connect circulator (120 volt, 5 amp maximum) between the blue wire and the white wire (neutral) (see Figure 22).

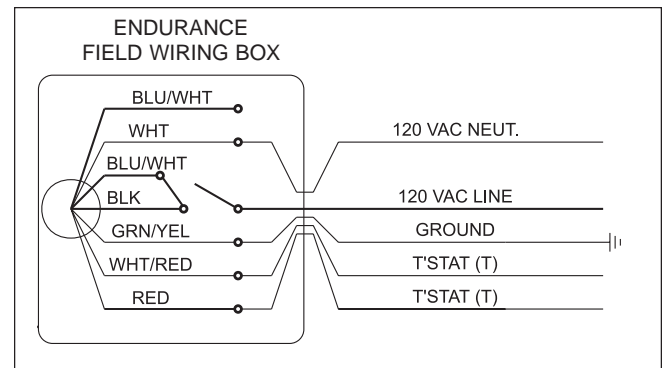

Figure 20. Single Zone With Room Thermostat (internal pump provides system flow).

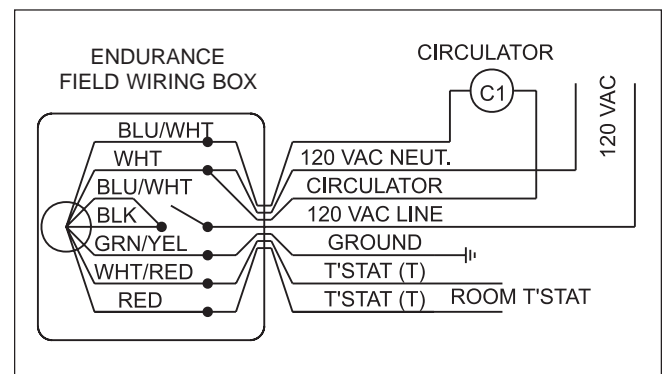

Figure 21. Single Zone with Added Circulator(s) and Room Thermostat(s).

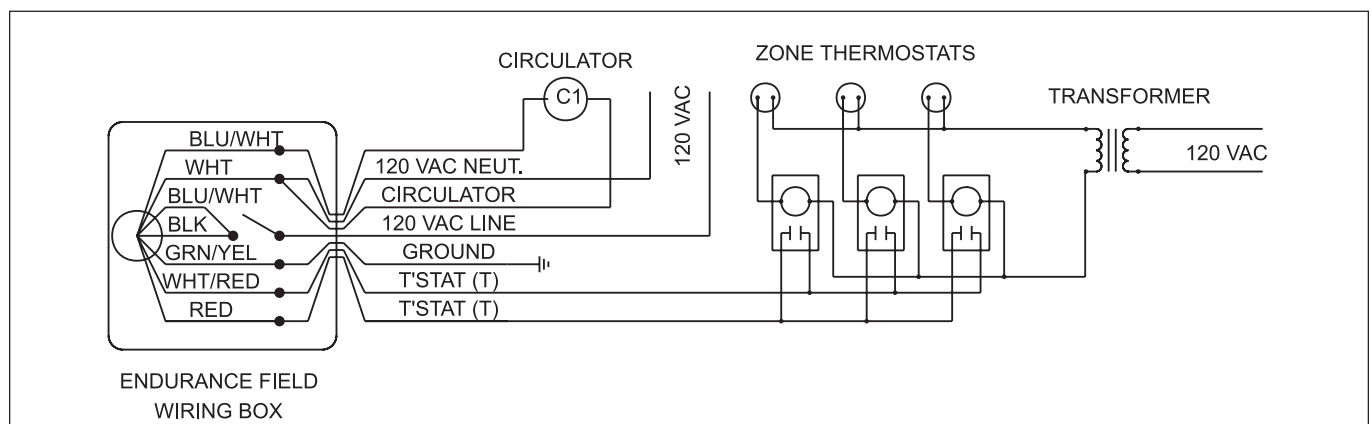

Figure 22. Multiple Zones Utilizing Four Wire Zone Valves with (Dry) End Switches.

4. Multi zone/Multi-relay-circulator Installations:  
Multiple circulators must not exceed 5 amps total when connected to blue wire (see Figure 24).

**NOTE:** On zone valve systems such as Taco, Automag and others which do not have isolated (dry) contact end switches, a single pole isolating relay must be utilized (see Figure 23).

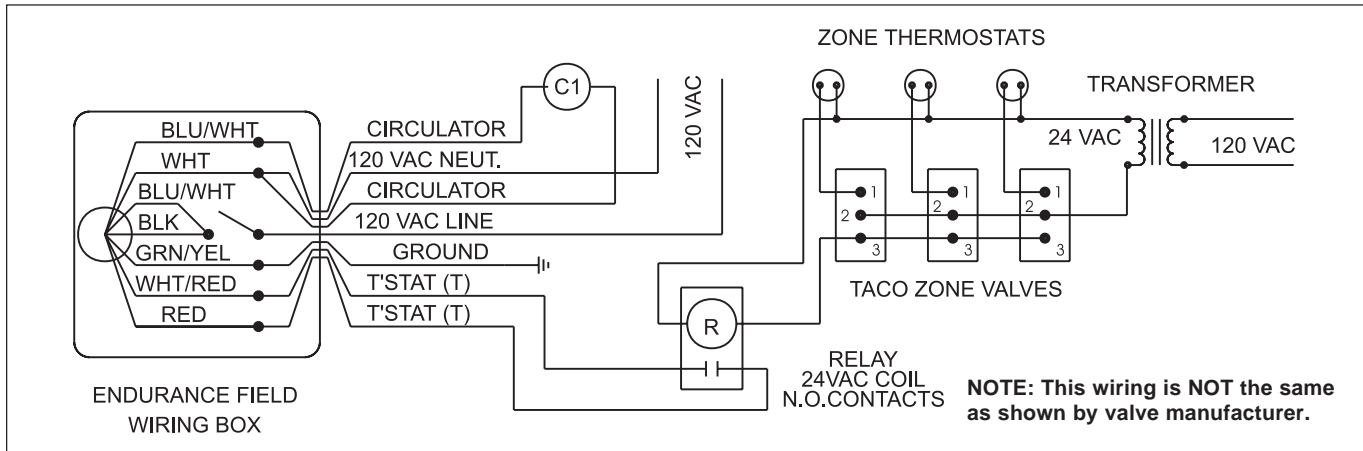

Figure 23. Multiple Zones with Three Wire Zone Valves (Requires Isolation Relay).

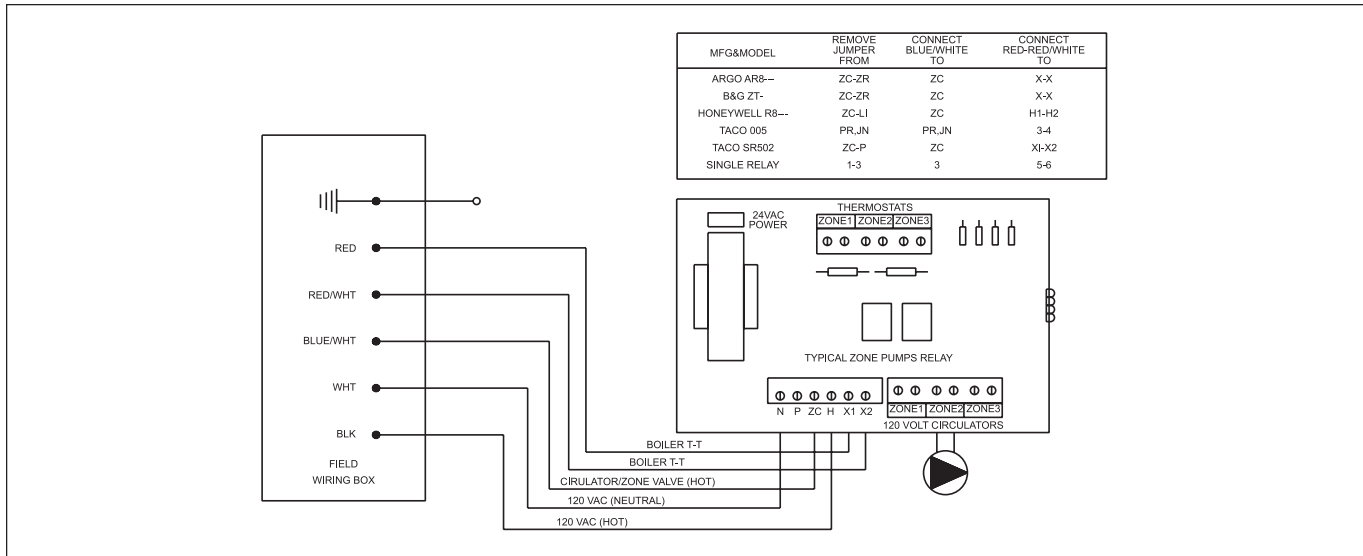

Figure 24. Multiple Zones with Circulators and Room Thermostats.

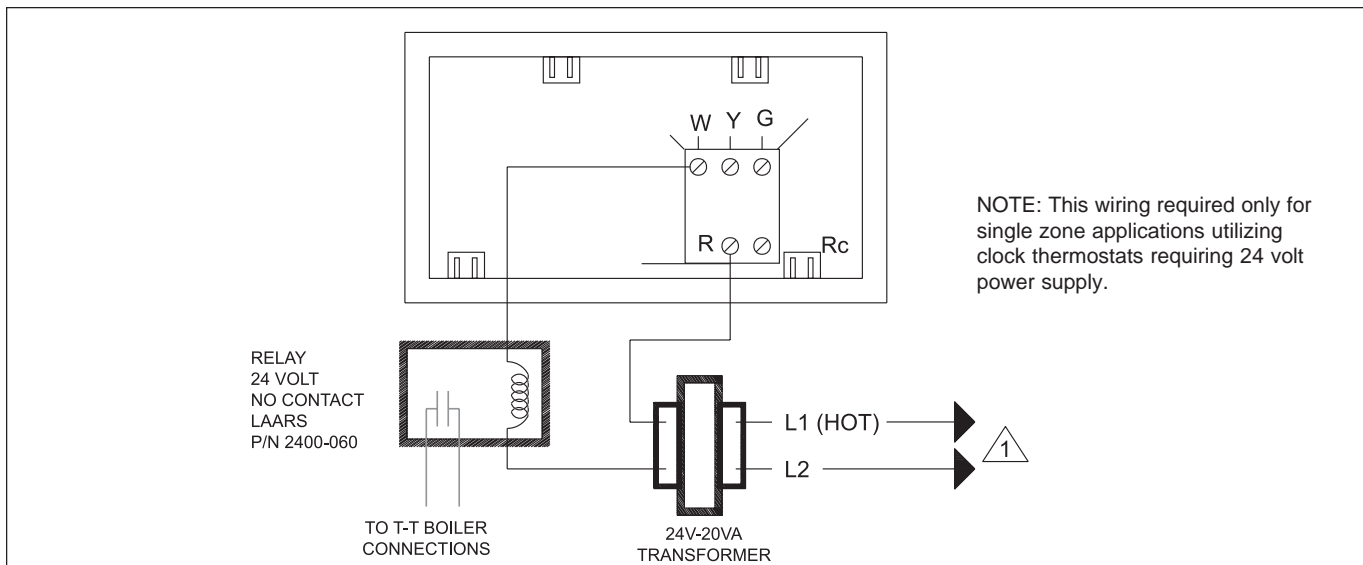

Figure 25. Wiring for Single Zone Power Stealing Type Clock Thermostats That Require 24 VAC.

## FOR YOUR SAFETY READ BEFORE OPERATING

### ⚠ WARNING

If you do not follow these instructions exactly, a fire or explosion may result, causing property damage, personal injury or loss of life.

- A. This appliance does not have a pilot. It is equipped with an ignition device which automatically lights the burner. Do not try to light the burner by hand.
- B. BEFORE OPERATING smell all around the appliance area for gas. Be sure to smell next to the floor because some gas is heavier than air and will settle on the floor.  
WHAT TO DO IF YOU SMELL GAS
  - Do not try to light any appliance.
  - Do not touch any electric switch; do not use any phone in your building.
  - Immediately call your gas supplier from a neighbor's phone. Follow the gas supplier's instructions.
- If you cannot reach your gas supplier, call the fire department.
- C. Turn off gas shutoff valve (located above the combination gas control) so that the handle is aligned across the gas pipe. If the handle will not turn by hand, don't try to repair it, call a qualified service technician. Force or attempted repair may result in a fire or explosion.
- D. Do not use this appliance if any part has been under water. Immediately call a qualified service technician to inspect the appliance and to replace any part of the control system and any gas control which has been under water.

## OPERATING INSTRUCTIONS

1. STOP! Read the safety information above on this label.
2. Set the thermostat to lowest setting.
3. Turn off all electric power to the appliance.

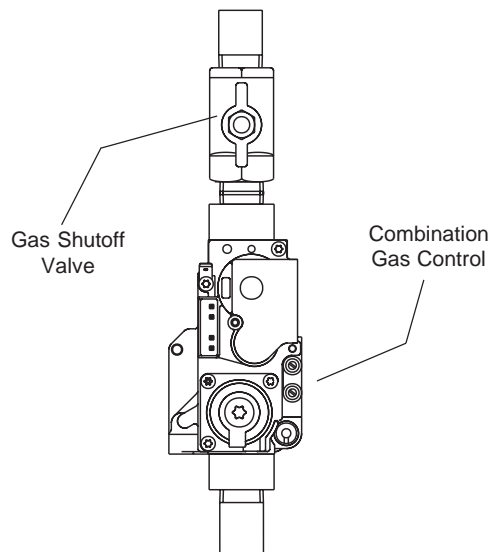

4. This appliance is equipped with an ignition device which automatically lights the burner. Do not try to light the burner by hand.
5. Remove control access panel, and top front cover.
6. Turn gas shutoff valve clockwise ↻ to "off". Handle will be horizontal, do not force.
7. Wait five (5) minutes to clear out any gas. If you then smell gas, STOP! Follow "B" in the safety information above on this label. If you don't smell gas, go to next step.
8. Turn gas shutoff valve counterclockwise ↺ to "on". Handle will be vertical.
9. Replace top front cover and control access panel.
10. Turn on all electric power to appliance, depress on/off button on control panel, depress black button on top of control panel.
11. Set thermostat to desired setting.
12. If the appliance will not operate, follow the instructions "To Turn Off Gas To Appliance" and call your service technician or gas supplier.

## TO TURN OFF GAS TO APPLIANCE

1. Set the thermostat to lowest setting.
2. Turn off all electric power to the appliance if service is to be performed.
3. Remove control access panel and top front cover.
4. Turn gas shutoff valve clockwise ↻ to "off". Do not force.
5. Replace top front cover and control access panel.

## PAR MESURE DE PRUDENCE, LISEZ CE QUI SUIT AVANT DE FAIRE FONCTIONNER L'APPAREIL

### ⚠ MISE EN GARDE

Si vous ne suivez pas ces instructions à la lettre, un incendie ou une explosion pourrait se produire et causer des dommages matériels, des blessures personnelles ou même la mort.

- A. Cet appareil n'est pas doté d'une veilleuse. Il est équipé d'un dispositif d'allumage qui allume automatiquement le brûleur. Ne tentez pas d'allumer le brûleur manuellement.
- B. AVANT D'UTILISER, vérifiez s'il n'y a pas d'odeur de gaz près de l'appareil. Vérifiez s'il n'y a pas d'odeur de gaz près du plancher, car le gaz est plus lourd que l'air et peut se déposer sur le plancher.
- QUE FAIRE EN CAS D'ODEUR DE GAZ
- N'essayez pas d'allumer n'importe quel appareil que ce soit.
  - Ne touchez pas à un commutateur électrique. N'utilisez pas le téléphone de votre résidence.
  - Appelez immédiatement votre fournisseur de gaz en utilisant le téléphone de votre voisin. Suivez les instructions de votre fournisseur de gaz.
- C. Fermez la soupape d'arrêt de gaz (située au-dessus de la commande de gaz multifonctions) de sorte que la poignée soit perpendiculaire au tuyau de gaz. Si vous ne pouvez tourner la poignée à la main, n'essayez pas de la réparer. Communiquez avec un technicien de service qualifié. Le fait de forcer ou de tenter de réparer la poignée pourrait causer un incendie ou une explosion.
- D. N'utilisez pas cet appareil si l'une des pièces a été plongée sous l'eau. Communiquez immédiatement avec un technicien de service qualifié afin qu'il inspecte l'appareil et remplace toute pièce du système de commande et toute commande de gaz qui aurait été plongée sous l'eau.

## NOTICE D'UTILISATION

1. ARRÊTEZ ! Lisez l'information de sécurité ci-dessus, sur cette étiquette.
2. Réglez le thermostat au réglage le plus bas.
3. Coupez l'alimentation électrique à l'appareil.
4. Cet appareil est doté d'un dispositif d'allumage qui allumera automatiquement le brûleur. Ne tentez pas d'allumer le brûleur manuellement.
5. Retirez le panneau d'accès aux commandes et le couvercle avant qui se trouve sur le dessus.
6. Faites tourner la valve de fermeture du gaz dans le sens des aiguilles d'une montre et mettez-la à «off». La poignée sera horizontale. N'employez pas de force.
7. Attendez cinq (5) minutes afin que le gaz se dissipe. Si vous croyez sentir une odeur de gaz, ARRÊTEZ ! Reportez-vous aux instructions B ci-dessous, sur cette étiquette. S'il n'y a pas d'odeur de gaz, passez à la prochaine étape.
8. Faites tourner la valve de fermeture du gaz dans le sens contraire des aiguilles d'une montre et mettez-la à «on». La poignée sera verticale.
9. Remplacez le couvercle avant et le panneau d'accès de commandes.
10. Rétablissez l'alimentation électrique à l'appareil, appuyez sur le bouton «on/off» qui se trouve sur le panneau de commande, appuyez sur le bouton noir qui se trouve sur le panneau de commande.
11. Réglez le thermostat à la température désirée.
12. Si l'appareil ne fonctionne pas, suivez les directives relatives à la fermeture de l'alimentation en gaz et communiquez avec votre technicien de service ou le fournisseur de gaz.

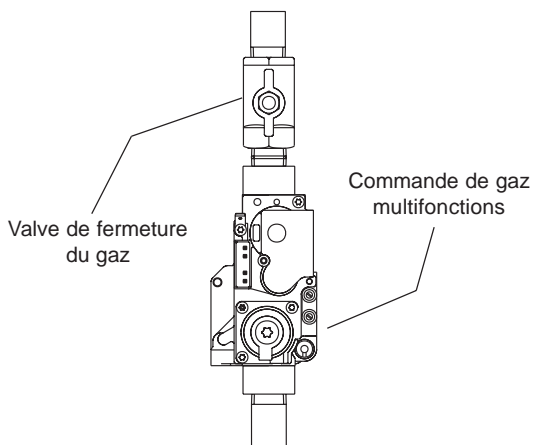

## FERMETURE DE L'ALIMENTATION EN GAZ

1. Réglez le thermostat au réglage le plus bas.
2. Coupez toute alimentation électrique à l'appareil si celui-ci doit faire l'objet d'un entretien.
3. Retirez le panneau d'accès aux commandes et le couvercle avant qui se trouve sur le dessus.
4. Faites tourner la valve de fermeture du gaz dans le sens des aiguilles d'une montre et mettez-la à «off». N'utilisez pas de force.
5. Remplacez le couvercle avant.



## SECTION 6. Boiler Start Up

### 6A. Common Vent Test

At the time of removal of an existing boiler, the following steps shall be followed with each appliance remaining connected to the common venting system placed in operation, while the other appliances remaining connected to the common venting system are not in operation.

1. Seal any unused opening in the common venting system.
2. Visually inspect the venting system for proper size and horizontal pitch and determine there is no blockage or restriction, leakage, corrosion and other deficiencies which could cause an unsafe condition.
3. Insofar as is practical, close all building doors and windows and all doors between the space in which the appliances remaining connected to the common venting system are located and other spaces of the building. Turn on clothes dryers and any appliance not connected to the common venting system. Turn on any exhaust fans, such as range hoods and bathroom exhausts, so they will operate at maximum speed. Do not operate a summer exhaust fan. Close fireplace dampers.
4. Place in operation the appliance being inspected. Follow the lighting instructions. Adjust thermostat so appliance will operate continuously.
5. Test for spillage at the draft hood relief opening after 5 minutes of main burner operation. Use

the flame of a match or candle, or smoke from a cigarette, cigar or pipe.

6. After it has been determined that each appliance remaining connected to the common venting system properly vents, when tested as outlined above, return doors, windows, exhaust fans, fireplace dampers and any other gas burning appliance to their previous conditions of use.
7. Any improper operation of the common venting system should be corrected so the installation conforms with the
  - a. National Fuel Gas Code, ANSI Z223.1 latest edition.
  - b. Can / CGA - B149.

When re-sizing any portion of the common venting system, the common venting system should be re-sized to approach the minimum size as determined using the appropriate tables in Appendix F in the National Fuel Gas code, ANSI Z223.1 - latest edition, and/or Can/CSA B149 Installation Codes.

### 6A. Common Vent Test

Au moment du retrait d'une chaudière existante, les mesures suivantes doivent être prises pour chaque appareil toujours raccordé au système d'évacuation commun et qui fonctionne alors que d'autres appareils toujours raccordés au système d'évacuation ne fonctionnent pas:

1. Sceller toutes les ouvertures non utilisées du système d'évacuation.
2. Inspecter de façon visuelle le système d'évacuation pour déterminer la grosseur et l'inclinaison horizontale qui conviennent et s'assurer que le système est exempt

Message	Identifies	To read or change mode
<i>bft</i>	Boiler Flow Temp (Supply)	During operation display will default to supply temperature. Press temperatures button repetitively. To sequence through three temperature indicators.
<i>ent</i>	Tank Temp	
<i>ret</i>	Return Temp (Boiler Inlet)	
<i>on</i>	On	Boiler in standby mode: will operate on call for domestic water or heat zone demand.
<i>OFF</i>	Off	Boiler switched OFF. Press ON/OFF button for "ON".
<i>LO</i>	Lock Out - Combustion Related	After three trials for ignition, will stand in lockout. Press reset on top of panel to retry.
<i>F-3</i>	Fault Code (Three) There are 8 different Fault Codes defined.	A fault code may be indicated on the display prior to pushing the reset button or switching the on-off button or power switch. Observe code, and note it, for servicing.
<i>ICE</i>	Freeze Protection	Sensor has detected return temperature below 39°F (4°C).

Figure 26. Typical Display Identification Codes.

- d'obstruction, d'étranglement, de fuite, de corrosion et autres défaillances qui pourraient présenter des risques.
3. Dans la mesure du possible, fermer toutes les portes et les fenêtres du bâtiment et toutes les portes entre l'espace, où les appareils toujours raccordés et les autres espaces du bâtiment. Mettre en marche les sècheuses, tous les appareils non raccordés au système d'évacuation commun et tous les ventilateurs d'extraction comme les hottes de cuisinière et les ventilateurs des salles de bain. S'assurer que ces ventilateurs fonctionnent à la vitesse maximale, Ne pas faire fonctionner les ventilateurs d'été. Fermer les registres des cheminées.
  4. Mettre l'appareil inspecté en marche. Suivre les instructions d'allumage. Régler le thermostat de façon continue.
  5. Faire fonctionner le brûleur principal pendant 5 min ensuite déterminer si le coupe-tirage déborde à l'ouverture de décharge. Utiliser la flamme d'une allumette ou d'une chandelle ou la fumée d'une cigarette, d'une cigare ou d'une pipe.
  6. Une fois qu'il a été déterminé, selon la méthode indiquée ci-dessus, que chaque appareil raccordé au système d'évacuation est mis à l'air libre de façon adéquate. Remettre les portes et les fenêtres, les ventilateurs, les registres de cheminées et les appareils au gaz à leur position originale.
  7. Tout mauvais fonctionnement du système d'évacuation commun devrait être corrigé de façon que l'installation soit conforme au *National Fuel Gas Code, ANSI Z223.1/NFPA 54* et (ou) aux codes d'installation *CAN/CGA-B149*. Si la grosseur d'une section du système devrait être modifiée pour respecter les valeurs minimales des tableaux pertinents de l'appendice F du *National Fuel Gas Code, ANSI Z223.1/NFPA 54* et (ou) des codes d'installation *CAN/CGA-B149*.
4. Purge all lines by opening vents.
  5. Close gas shutoff valve located above gas valve.
  6. Turn on 120 volt power, the display will initially display [---] for five seconds before displaying [OFF].
  7. If the temperature sensor detects a temperature below 39°F (4°C) it will display [ICE]. The appliance will then be in the frost protection mode. The pump initially runs alone for 5 minutes or until the flow temperature reaches 45°F (7°C). (EBP ONLY: When the internal zone valve is manually\* opened the water will be pumped to the space heating.) This is a good time to ensure that the system is fully discharged of all air and the water charge pressure is correct. Should the water temperature remain below 45°F (7°C) after 5 minutes the appliance will start the ignition sequence. After three attempts to ignite the burner control will lock out and display [LO] (see Figure 25).
  8. If the display remains at [OFF], press the on/off button on the front panel and the reset button on top of the front panel. The pump and the blower will start, the display will then flash [bFE] (boiler flow temperature) for 1 second intervals and the actual temperature (e.g., [127]) in degrees F for 3 second intervals. The appliance will attempt to ignite three times after which it will lock out and display [LO]. The fan and the pump will then stop. Ensure that the system is fully discharged of all air and the water charge pressure is correct.
  9. Turn the main electrical supply off.
  10. **EBP ONLY: Manually reset the internal zone valve to its normal position (manual level toward top of actuator).**
  11. System is now ready for operation.

## 6B. Filling the System

1. Open all supply and return valves.
2. Fill heating system to minimum operating pressure 12 psig.
3. Loosen screw in coin vent and allow any trapped air to escape. Collect any water that escapes so that it does not drip on the blower electronics and damage them. Small amounts of air that may remain will be purged by the internal pump. Tighten screw after purging.

\*The "manual operation" lever located on the side of the valve operator requires moderate pressure to latch the valve open and then again to unlatch it and allow it to close.

## 6C. Firing Burner

1. Be sure that system has been filled properly and is leak tight.
2. Open gas shutoff valve.
3. Turn on main electrical switch.
4. If the temperature sensor detects a temperature below 39°F (4°C) it will display [ICE]. The appliance will then be in the frost protection mode.
5. If the display remains at [OFF], press the on/off button on the front of the control panel and the reset button on top of the control panel.
6. The pump and the blower will start, the display will show [bFE] (boiler flow temperature) for 1 second intervals and the actual temperature (e.g., [127]) in degrees F for 3 second intervals.

The appliance will attempt to ignite three times, if ignition is not successful, the appliance will lock out and display [L0]. Ignition reset is done by pressing the reset button on top of the control panel. EBP models will then operate to heat the transfer tank.

7. EBP ONLY: Turn on a hot water tap. This puts the appliance in the DHW mode.

### Caution

Should any pronounced odor of gas be detected, or if the gas burner does not appear to be functioning in a normal manner, close main shutoff valve, do not shut off switch, and contact your heating contractor, gas company, or factory representative.

You MUST check flame monitoring control (ignition system safety shut off device).

1. Close gas shutoff valve with burner operating.
2. The flame indicator light will go out and blower will continue to run for the post purge cycle. Three additional attempts to light will follow including pre-purge, ignitor on, valve/flame on and post purge. Ignition will not occur as the gas is off. The display will eventually show [L0] approximately 10 seconds after the gas valve has closed on the third ignition attempt.
3. Open gas shutoff valve. Press reset button on the top of the control panel. The ignition sequence will start again and the burner will start. The appliance will return to its previous mode of operation.

## 6D. Mode and On/Off Buttons Operation

The on/off button is used to switch the appliance from standby [ON] to standby [OFF] and vice versa. It is NOT an isolation switch. The mode button accesses all other functions as described in their particular sections of this manual.

## SECTION 7. Maintenance and Component Description

### 7A. Unit Pump

The unit pump operates whenever there is a call for heat or hot water.

It is a wetted-rotor type pump and should always be filled with water when it is operating so that it will cool properly.

If a pump change is required for any reason, valve off the boiler and drain approximately 1 or 2

gallons (approx. 4-8L) of water from it. Turn off the main disconnect switch and unplug the pump wires, remove the pump motor. The pump housing need not be removed. The replacement pump motor should be installed in the reverse order from which the old pump motor was removed. After filling the system be sure the combustion chamber coil vents through the air vent located on top of the boiler chamber (inlet manifold extension).

### 7B. Gas Valve

The gas valve is a 24VDC solenoid operated, negative pressure regulated ratio valve. The outlet pressure may be adjusted as described in the service section. It is designed to operate with supply pressures of 4-13 inches w.c. (1.0 to 3.2 kPa). To remove the gas valve, shut off 120 volt power and the gas shutoff valve, remove the 4 screws on the upper and lower flanges and disconnect the wires from the gas valve, the valve may now be removed. After the valve has been removed, replace with a new valve in the reverse order in which the old valve was removed. Turn on gas shutoff valve and 120 volt power and check boiler operation and gas tightness of gas valve connections.

### 7C. Safety Limit Switch

The Safety Limit Switch is an automatic reset switch with a fixed set point of 230°F (110°C). To replace the switch, shut off the 120 volt power. Disconnect the 2 wires from the quick connects at the switch and remove the switch. To replace, perform the same operations in reverse. Turn on disconnect switch and check boiler.

### 7D. Boiler Control Printed Circuit Board (PCB)

The Integrated Boiler Control Module controls the ignition process, the combustion process, the temperature of the boiler flow and return, and the transfer tank temperature\* and provides both domestic hot water\* and space heating on demand.

To do this it takes inputs from three temperature sensors, a domestic hot water flow switch, an overheat thermostat (safety limit) and an external space heating switch, such as a room thermostat, zone valve end switches or circulator relay contacts. It then controls the pump, blower, ignitor and gas valve sequencing.

It constantly displays the boiler outlet temperature when the appliance is operating in one of its demand modes. It also allows the user to obtain information from the appliance to determine the water temperature at three different locations within the appliance and to find up to 8 previous faults stored in memory.

If replacement of PCB is necessary, shut off the 120 volt power and disconnect the wire connectors from the pcb. Remove the PCB from its location posts.

Replace in reverse order ensuring that the connections are correct.

\*EBP combination units only.

## 7E. Ignitor / Flame Sensor Assembly

The ignitor is a “glow bar” type ceramic composite device. It is energized whenever there is a call for heat and switched off when ignition is established.

The flame sensor is a remote sensing flame rod which is connected directly to the circuit board “J5” terminal. The ignitor should read 50 to 100 ohms resistance when at room temperature.

If the ignitor fails and the assembly must be replaced, always install a new ignitor gasket with the replacement assembly.

For sequence of operation, see Section 8, Servicing.



## 7F. Transformer

The control transformer accepts 120 VAC line voltage and provides 80 VA of 24 VAC control voltage for the boiler control ONLY. It is NOT capable of supplying control voltage for external devices such as zone valves, which MUST have their own separate power supply.

Should the transformer require replacing, shut off the 120 volt power. Unplug the transformer wires from the PCB, unscrew the two fixing screws and remove the transformer.

Fit the replacement transformer in reverse order.

## 7G. Blower

The combustion air blower is a high pressure centrifugal blower. It is powered by a 24VDC motor which is controlled by the PCB. Its speed will be varied according to the temperature of the boiler flow.

If a blower change is required, turn off the 120 volt power and unplug the wires from the blower motor. Remove the four nuts from the blower discharge flange and the four screws that secure the gas manifold to the gas valve. Remove the complete assembly. Unscrew the combustion air inlet assembly and register plate from the fan.

Fit the replacement fan in reverse order, ensuring that all joints are made correctly and sealed.

After replacement the combustion should be checked for correct air fuel ratio (see Check, Test and Start-Up section).

## 7H. Transfer Tank (EBP)

The transfer tank contains approximately 20 gallons of boiler water. It functions as an energy

storage vessel to reduce boiler cycling on small output heating zones and to provide additional heat for domestic hot water through the domestic hot water (DHW) plate heat exchanger.

If a tank change is necessary, access to the tank is possible by removing the jacket’s lower front panel. This is done by removing the screws that hold the panel at the top and lifting the panel away. Isolate the appliance and drain down using the drain cock at the base of the tank. Remove the tank sensor. Undo the union and the pump flange bolts that connect the tank to the boiler, unscrew the panel between the upper and lower compartments, support the upper components and remove the tank. Installation of the new tank is done in the reverse order. After installation purge all air from the boiler before restarting.

## 7I. Thermostatic Union (EDP/EDN)

The thermostatic union is a 1¼" NPTF union which must be mounted at the flow outlet to control boiler temperature. The union must be installed so that union nut is on the boiler side of the connection. This insures that the thermostat is properly positioned with its spring facing up, toward the system. The element has two small bypass holes that allow some water to flow into the system at all times. When the boiler first starts and the element is closed, boiler water is re-circulated back to the return until the supply water reaches 160°F (71°C). The element then modulates open. If the temperature does not exceed 150°F (66°C) within two minutes after firing, the element is not functioning properly. To replace the element, shut off and drain the section of the system adjacent to the thermostatic union. Open the union and replace the element with a new one. The element should be installed so that its spring and actuator are facing the system side (up). Close the union, open the valves, refill and bleed the system. Ensure that air is venting from the air vent on top of the boiler chamber and it is left operational. Restart boiler.

## 7J. Cleaning the Boiler Coil

The Endurance is equipped with a premixed combustion system. This type of combustion system does not create free carbon (soot) except in very rare instances and therefore the combustion chamber coil will probably never need cleaning. If cleaning is required, proceed as follows: valve off the boiler, switch off the electrical power at the disconnect switch, drain 1-2 gallons (4-8L) of water from the boiler drain, remove the flue assembly from the top of the boiler, remove the pump flange bolts from the top pump flange, disconnect the sensor wires from the sensors (boiler flow, return and safety limit), undo the union nut from the boiler flow manifold, and remove the four (4) screws from the bottom gas valve flange. The boiler assembly may now be removed from the jacket. After removal of the boiler assembly from the

jacket, remove the four (4) long screws that secure the top and bottom pans. Remove the air vent and the top pan. Remove the insulation retainer and the coil cover insulation. Clean the boiler coil with a wire brush and vacuum debris from the combustion chamber (avoid hitting the ignitor or the flame sensor with the brush or vacuum hose because they are fragile).

After cleaning, assemble the parts in the reverse order, open isolation valves and bleed air from the boiler and the system. Follow the lighting instructions and start the boiler. Check operation.

## SECTION 8 Servicing.

### 8A. Sequence of Operation

Figures 22 and 23 depict the flow paths and temperature sensor locations for the space heating, EDP/EDN, and the combined space heating and domestic water heating, EBP, appliances.

The model EDP/EDN modulating boilers are cold start boilers that will start only on a call for heat from a room thermostat or zone control contact. During normal operation the Message Center [MC] LED display will indicate 'ON' while awaiting a call for heat. On a call for heat the following sequence will occur.

1. (a) The internal pump will start.
- (b) After 5 seconds the blower prepurge cycle will start and operate for approximately 6

seconds while the [MC] indicates alternately *bFl* and the current boiler outlet temperature.

2. Following the prepurge cycle the ignitor will heat for 10 seconds while the blower continues to operate.
3. The gas valve will then be energized (green 'GV' LED located on the PCB next to the display will light) and open, gas will flow and ignition will occur.

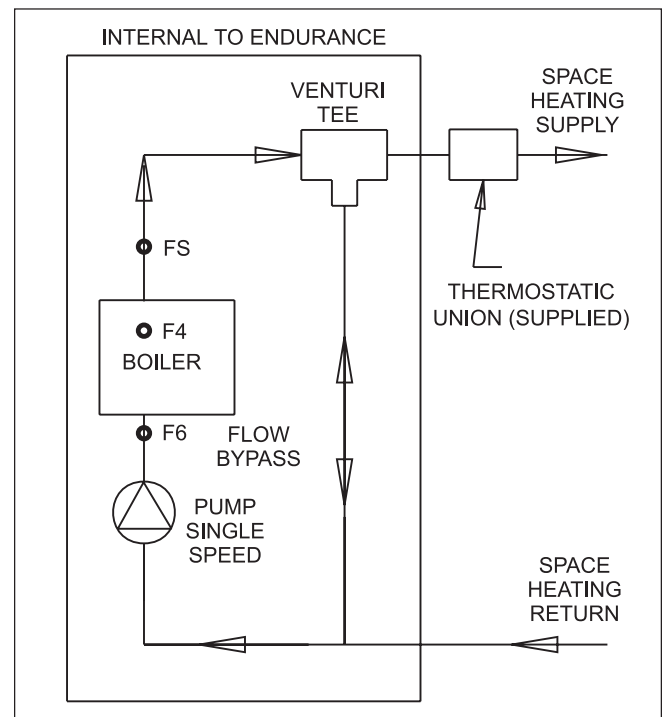

Figure 27. EDP/EDN Flow Schematic.

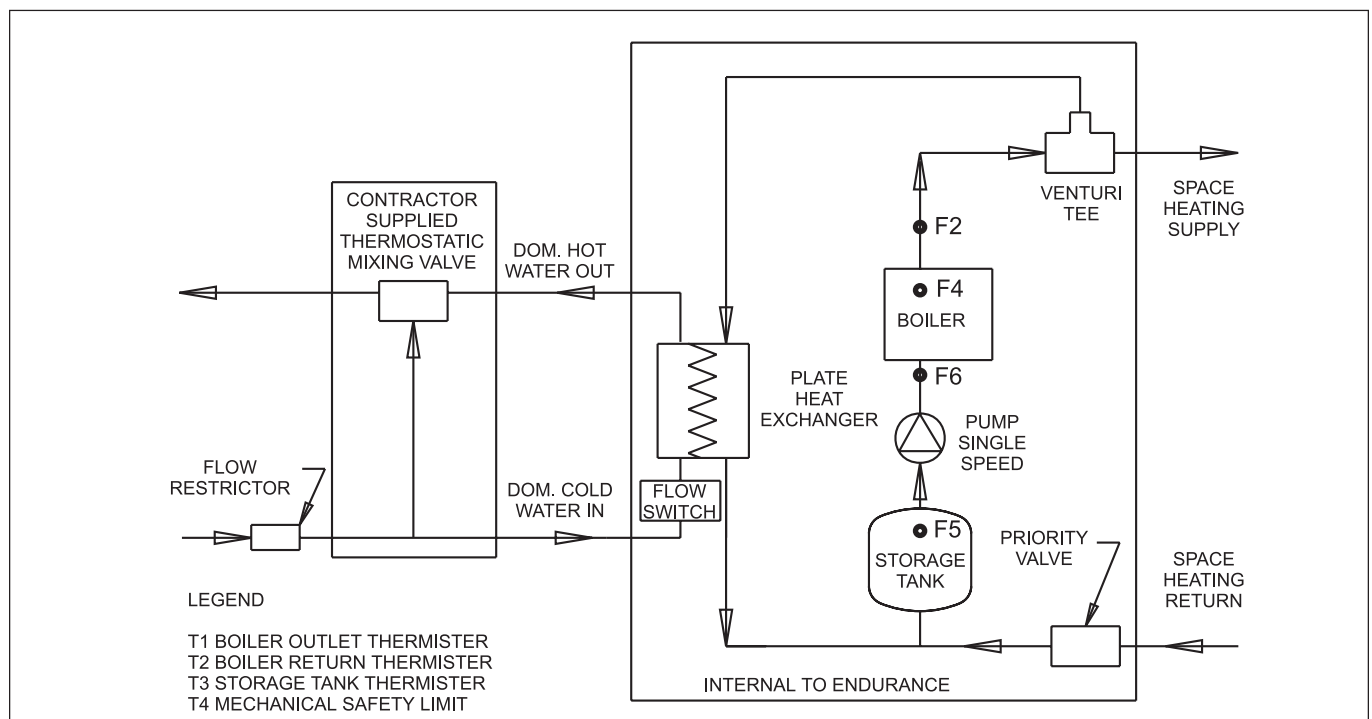

Figure 28. EBP Flow Schematic.

4. 10 seconds after establishing combustion and proof of flame ( via the flame rod signal to ground ), the ignitor will be de-energized and the burner will modulate to high fire for maximum output.
5. The [MC] should indicate a rapid rise in temperature to 150° F (1-2 min. duration). During this period the thermostatic union at the flow outlet is closed and the boiler is operating in the internal recirculation mode. [Service note: If the temperature rise is not rapid the union thermostat may be defective and must be replaced].
6. At 150° F the thermostat will allow increased flow to the system and a gradual rise in temperature will be indicated until the temperature approaches the setpoint temperature of 180°F. The firing rate will start to modulate downward until its cutoff limit is reached or the call for heat is satisfied.

The EBP modulating combination boiler will start from any of three input signals: (a)T-T closure for space heating. (b)A demand for domestic hot water, signaled by water flow activation of the water flow switch. (c)A call for heat from the minimum tank temperature sensor at 158°F (tank charge mode). In tank charge mode the red LED located below the green LED on the PCB will be lit. In modes (b) and (c) which are priority modes, the internal anti-condensing valve will be closed. On a T-T call for heat the valve will remain closed until the priority modes are satisfied.

[Service note: as with the thermostatic union in the EDP/EDN models, the anti-condensing valve prevents condensation on the combustion chamber coil and must be in the closed position when the coil inlet (F6) indicates a temperature below 130°F].

## 8B. Trouble Shooting - Fault Codes

The Endurance boiler is controlled by a Pactrol integrated boiler control (PCB) which provides eight fault codes with eight memories. To obtain fault messages press-in on the message center fault button until the first fault code (FL1) is displayed.

If a thermistor error occurs, it will appear on the LED upon power-up. **The memory does not need to be accessed. Memory fault codes are for error history only. All thermistor faults will show as “F” codes on the LED, and will never cause the LED to read “LO”.** (Note that the unit is shipped with error codes already in memory, and an error code that is shown in memory upon start-up of a new unit is from manufacturing testing.)

The last recorded fault will appear e.g. F-4 (flow thermistor faulty - open or shorted). The control will then sequence through all eight memories, indicating alternately the fault number and the fault code (FL1,

F-?; FL2, F=?; ..., FL8, F=?). The fault number in fault code FL1 is the most recent fault.

### 8B-1. Fault Code Identification

The following eight fault codes may be observed:

- F- Error corrected, control in auto reset time period (10 seconds)
- F-0 No fault has occurred
- F-1 Error occurred reading fault logic of main control
- F-2 Over heat thermostat has operated (open circuit)
- F-3 Fan fault
- F-4 Flow temperature sensor faulty (open or short circuited)
- F-5 Tank temperature sensor faulty (open or short circuited) (Combi unit only)
- F-6 Return temperature sensor faulty (open or short circuited)

### 8B-2. Fault Correction (see also Fault Trees in this Section)

- F-1 Switch off boiler and restart. If F-1 repeats, replace PCB
- F-2 The overheat thermostat (safety limit) opens at 230°F. Observe boiler operation if the boiler shuts off before the **bFt** indicates 225°F (107°C) replace safety limit. If the temperature rises rapidly and the safety limit operates, the internal pump is not operating. Refer to the wiring diagrams and check for voltage (120V) across the terminals on the PCB marked PMP.
  - a. If there is no voltage, and the PCB display does not indicate on or off, replace PCB
  - b. If there is voltage, the pump or wiring is defective.
- F-3 Attempt to start the boiler. Check combustion air blower operation. If F-3 is indicated again, replace blower.
- F-4 Check for damaged wiring or poor connection at sensor plug. If they are OK disconnect the sensor plug and check the resistance across the sensor terminals. The resistance of a good sensor is 10,000 ohms @ 77°F (25°C). Replace sensor if resistance is less than 500 or more than 20,000 ohms.
- F-5 Correct in the same manner as F-4.
- F-6 Correct in the same manner as F-4.

### 8B-3. Resolving Lockouts (LO)

(The memory does not need to be accessed.

**Memory fault codes are for error history only. All thermistor faults will show as “F” codes on the LED, and will never cause the LED to read “LO”.**

There are many causes for lockouts. The five most common causes are: (1) poor combustion,

### POWER UP FAULT TREE

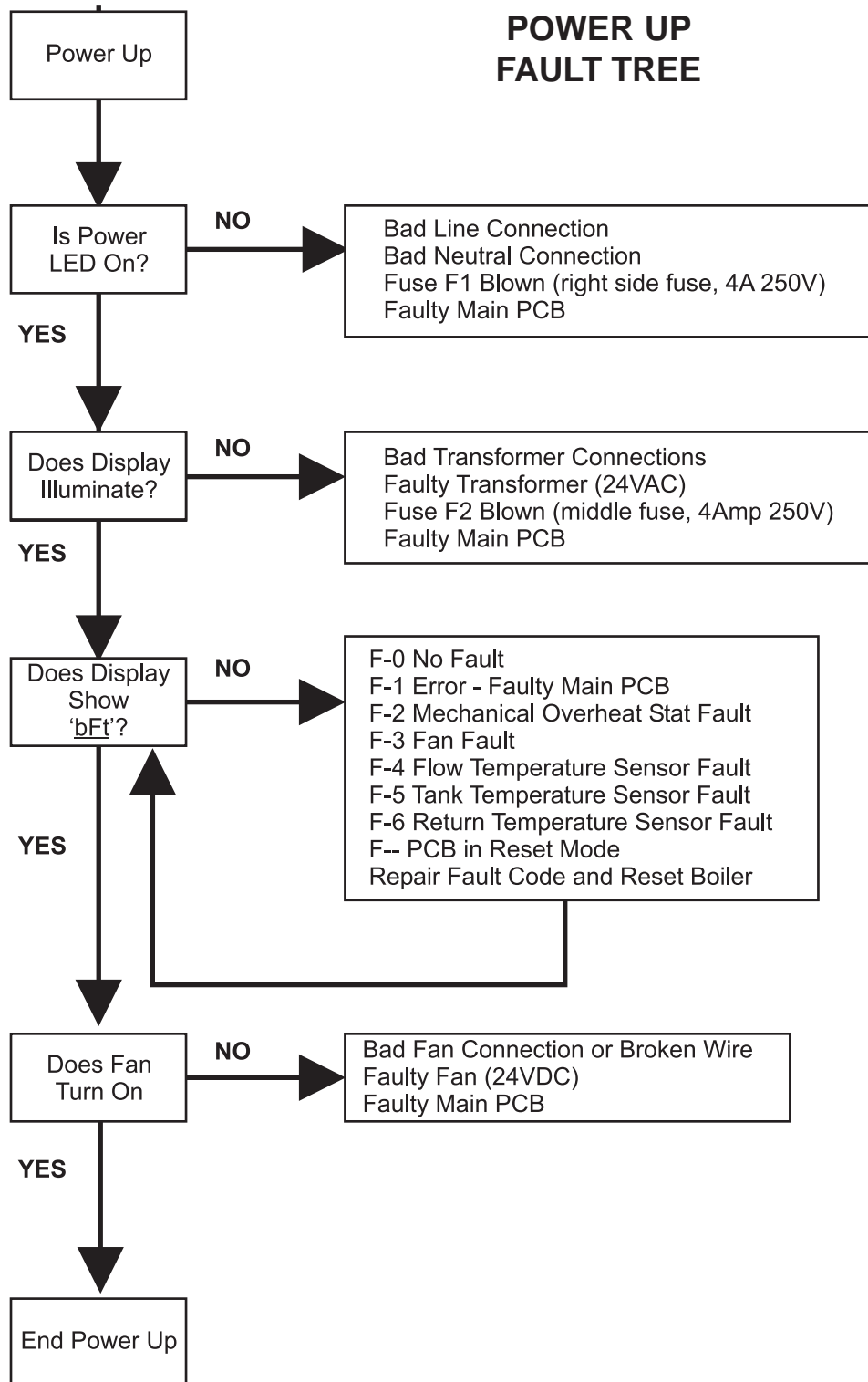

### IGNITION FAULT TREE

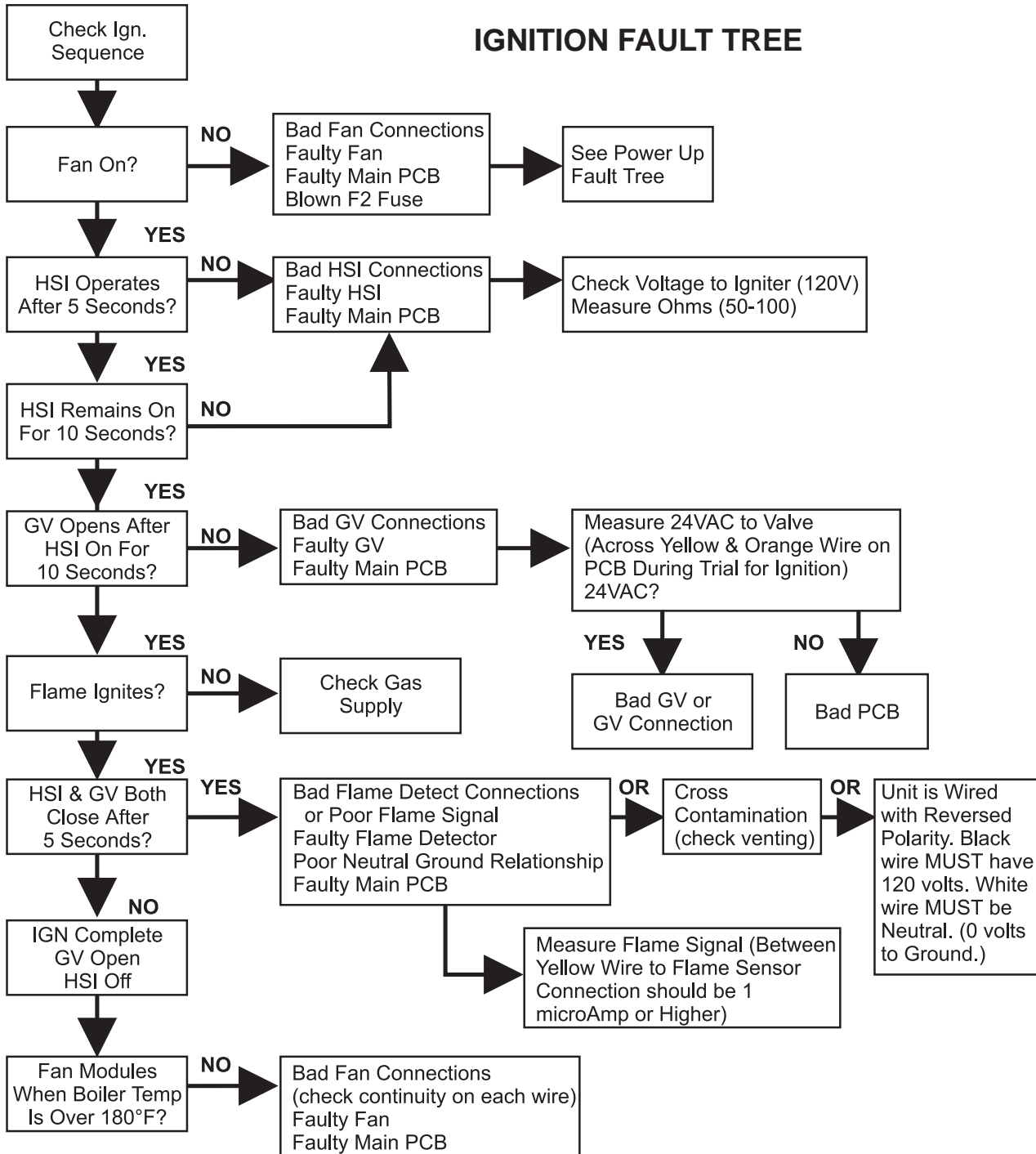

NOTE:  
 GV = Gas Valve  
 HSI = Ignitor  
 LO RESET = Reset Button

	Anti-Condensing	Pump	Tank LED
For Tank Charge	CLOSED	ON	ON
DHW	CLOSED	ON	OFF
Hydronic Heating	OPEN	ON	OFF



## SPACE HEATING FAULT TREE

NOTE:  
 ACV = Anticondensing Valve  
 MFS = Water Flow Switch  
 PCB = Main Control Board

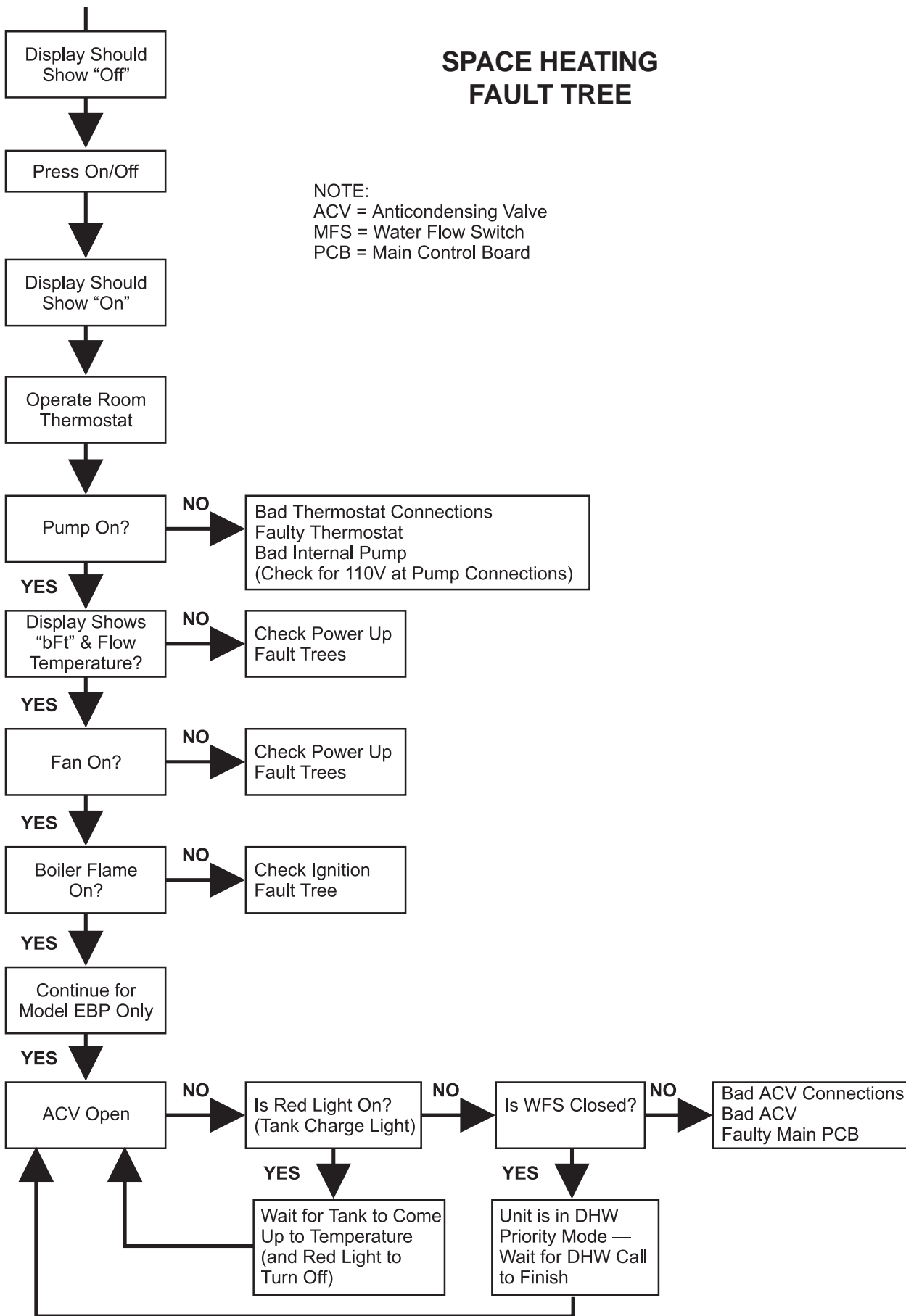

### DOMESTIC HOT WATER FAULT TREE (EBP ONLY)

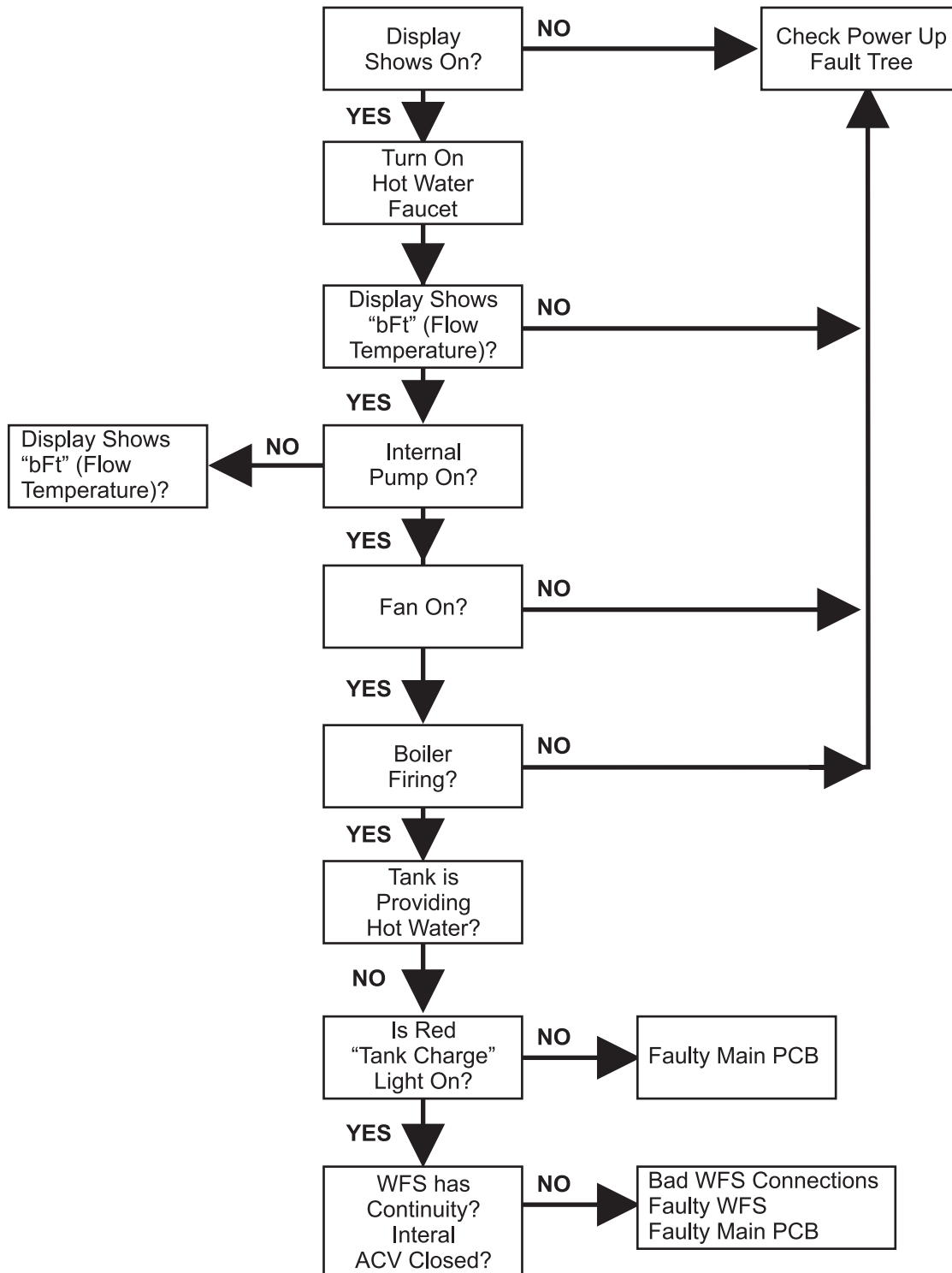

NOTE:  
 ACV = Anticondensing Valve  
 WFS = Water Flow Switch  
 PCB = Main Control Board

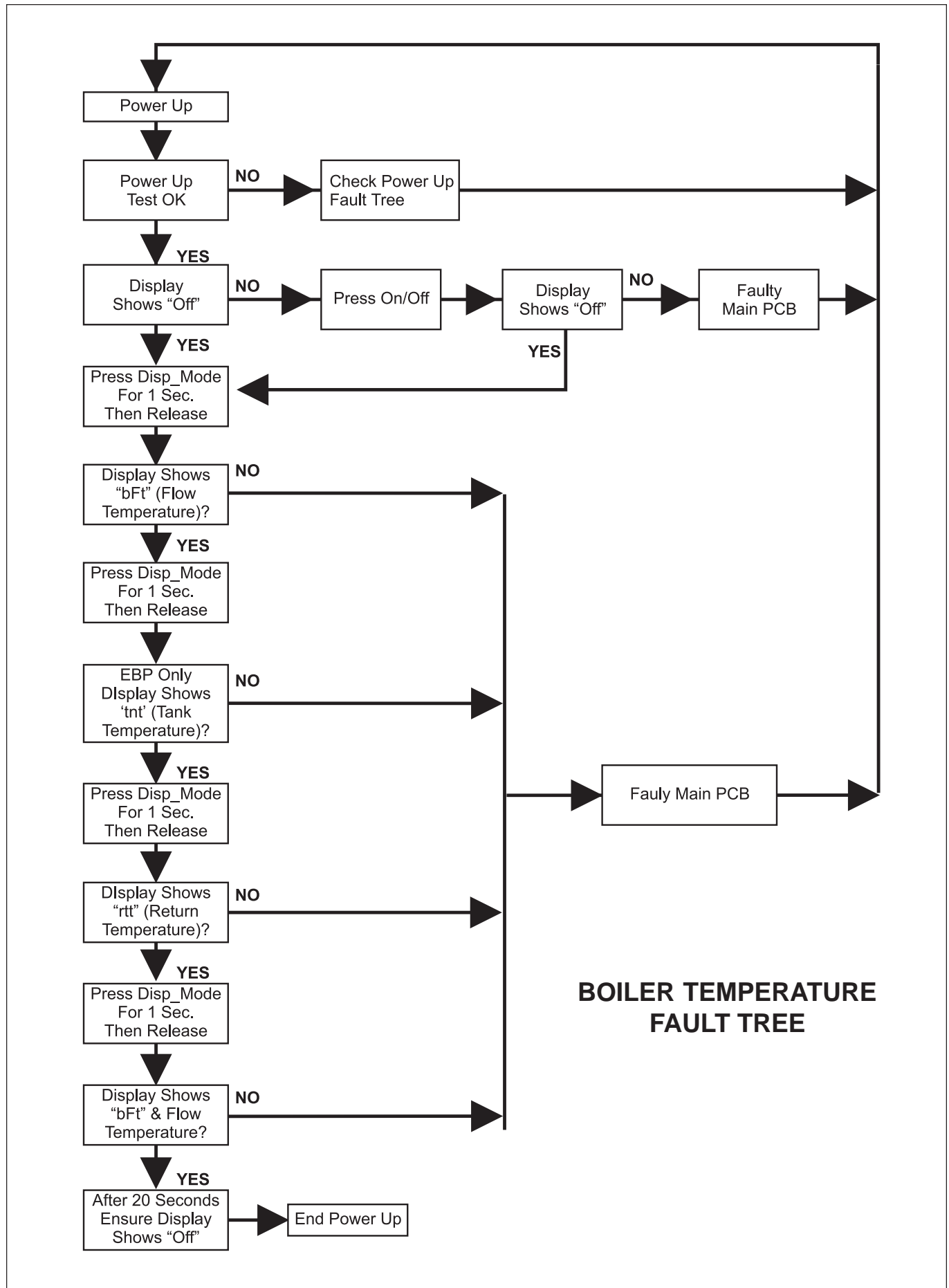

(2) poor flame sensor signal, (3) inadequate gas supply, (4) ignitor failure, (5) blocked or contaminated air source.

1. **Poor Combustion:** Poor combustion should be suspected if there is a strong flue gas odor. The odor may result from either an improper gas/air ratio (high or low CO<sub>2</sub>) or contamination of the combustion air supply. If an improper gas/air ratio is suspected refer to “gas valve calibration (offset adjustment)” on page 25. If contamination of the air source is suspected refer to (5) below.
2. **Poor flame sensor signal:** The boiler control board will lockout if the flame sensor is grounded or if the flame signal it receives is less than 1  $\mu$ A dc. To check for a grounded sensor, remove the flame sensor wire (yellow) from the boiler control board and check for continuity between the yellow wire terminal and the combustion chamber bottom pan. If there is continuity, the flame sensor is grounded. An alternate way to check for grounding of the flame sensor is to check the ohms resistance between the yellow wire terminal and the combustion chamber bottom pan, using a meter set for at least 100,000 ohms. The resistance must be more than 250,000 ohms (some technicians have been confused by meters which report infinite resistance with what appears to them as double zeros; an infinite resistance reading means there is no grounding of the flame sensor.) If there is continuity, or the ohms resistance is less than 250,000 ohms, debris or moisture in the combustion chamber may be the cause. To correct, carefully remove the ignitor and flame sensor assembly. Look for debris on the assembly where the flame rod exits the ceramic tube. If debris exists, remove it. If this area is clean, insert a pencil or other round object into the flame sensor hole in the bottom combustion chamber pan and roll it around to clear any debris that may exist inside the combustion chamber. Replace the ignitor/flame sensor assembly, reconnect the yellow wire on the PCB and start the boiler. If lockout persists, check the flame signal. To check the flame signal, disconnect the yellow wire from the flame sensor, connect a meter, set for microamps ( $\mu$ A) DC, between the flame sensor connector and the yellow wire connector. Start the boiler. If the meter reading is less than 1.00  $\mu$ A DC, see (3) “poor combustion” below. (Check for air leaks at air inlet to blower.)
3. **Inadequate gas supply:** Before proceeding, ensure that the gas supply has not been shutoff or the LP tank (LP boilers) is not empty. Then, reset the boiler and observe the operational

### MEASUREMENTS AT HIGH FIRE

NATURAL GAS	
% CO <sub>2</sub>	9.0 - 9.6
MAX INPUT BTU/H	175,270
OFFSET IN W.C.	(-0.01 to -.10)
LP GAS	
% CO <sub>2</sub>	9.7 - 10.1
MAX INPUT BTU/H	175,270
OFFSET IN W.C.	(-0.01 to -.10)

Table 4. EBP/EDP 175.

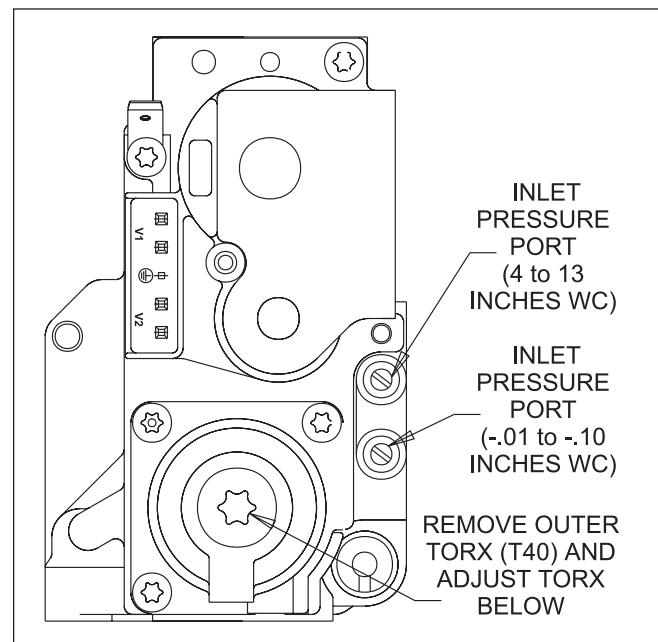

Figure 29.

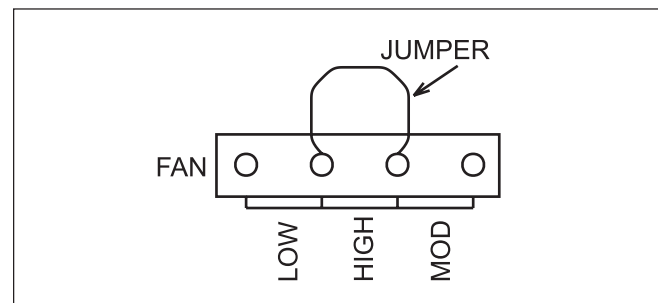
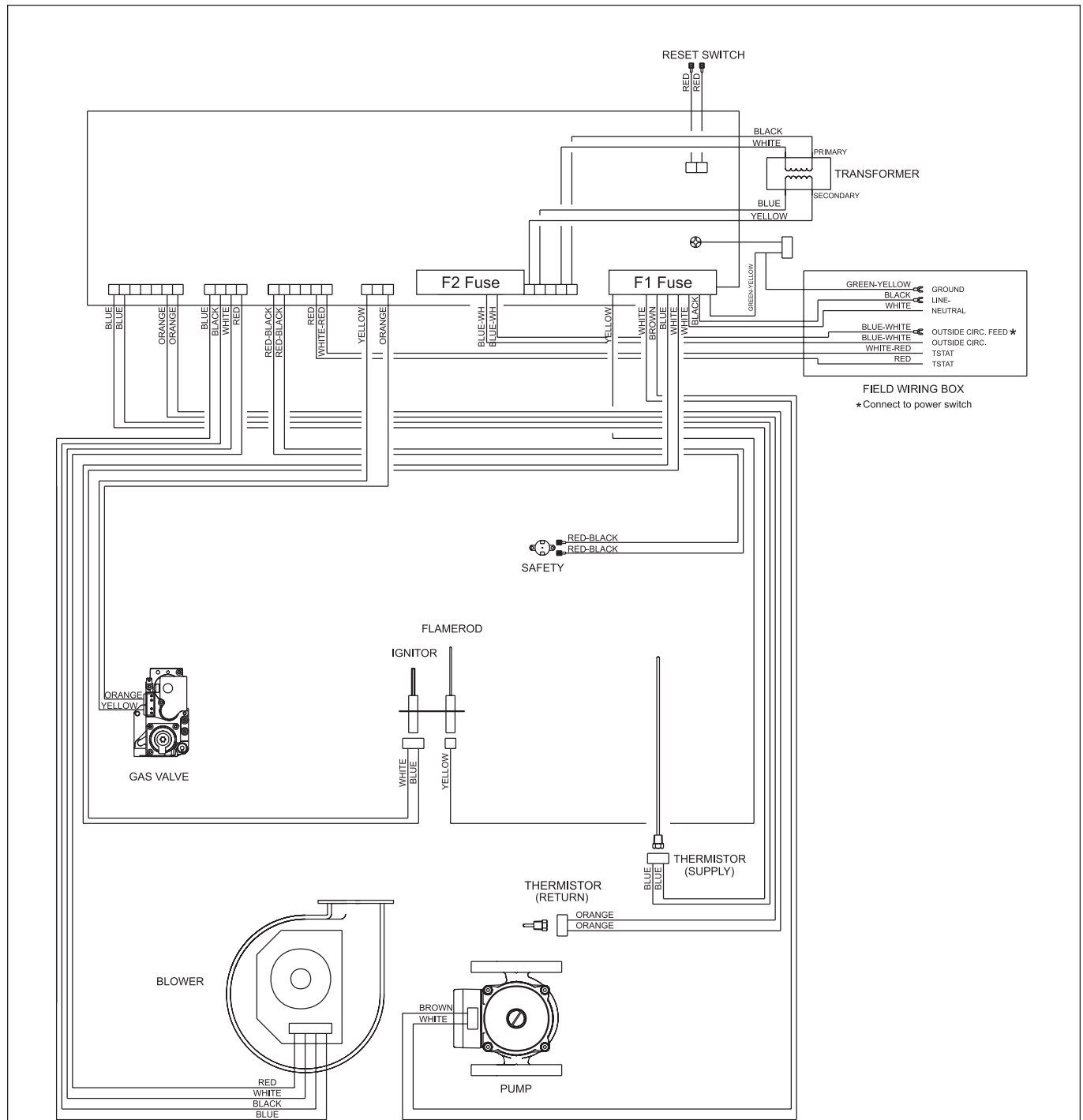

Figure 30. Jumper Wiring for Test and Calibration.

cycle. Approximately 20 seconds after the start of the cycle, the GV LED on the PCB should light. If it does not, reset the boiler and check for 24 VAC at the plug on the PCB. If the voltage is less than 20 VAC, and transformer voltage is 24 VAC replace the PCB. If the voltage is correct, connect a pressure gauge to the offset pressure port on the gas valve. Reset the boiler and



40-426A

**⚠ Caution**  
 Label all wires prior to disconnection when servicing controls. Wiring errors can cause improper and dangerous operation.  
 Verify proper operation after operation servicing.

**⚠ ATTENTION**  
 Au moment de l'entretien des commandes, étiquetez tous les fils avant de les débrancher. Les erreurs de câblage peuvent nuire au bon fonctionnement et être dangereuses.  
 S'assurer que l'appareil fonctionne adéquatement une fois l'entretien terminé.

Figure 31. EDP/EDN Wiring Diagram.

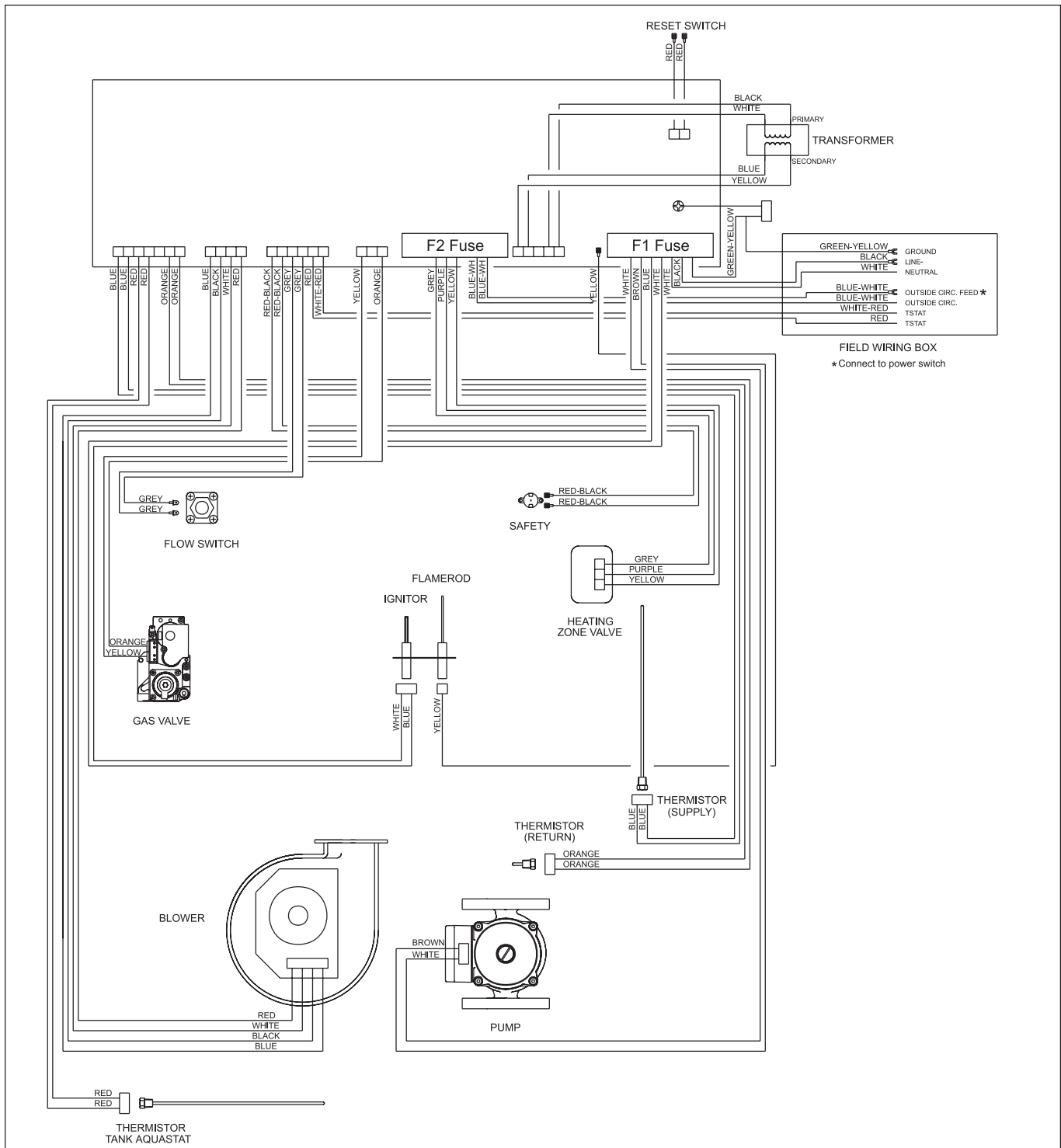

30-426A

**Caution**

Label all wires prior to disconnection when servicing controls. Wiring errors can cause improper and dangerous operation.

Verify proper operation after operation servicing.

**ATTENTION**

Au moment de l'entretien des commandes, étiquetez tous les fils avant de les débrancher. Les erreurs de câblage peuvent nuire au bon fonctionnement et être dangereuses.

S'assurer que l'appareil fonctionne adéquatement une fois l'entretien terminé.

Figure 32. EBP Wiring Diagram.

observe the offset pressure at startup and after 20 seconds. The pressure will be ~ -2 in. w.c. at startup (during prepurge) and should become less negative (-0.1 in. w.c.) when the gas valve opens and gas flow starts. If the pressure remains at ~ -2 in. w.c. throughout the cycle replace the gas valve.

4. Ignitor failure: If the boiler goes through a normal start cycle but combustion does not occur, ignitor failure should be suspected. Check the ignitor by unplugging the ignitor plug and measuring the ignitor resistance. It should be 50-100 ( $\Omega$ ) ohms. If the resistance is not 50-100 ohms ( $\Omega$ ), replace the ignitor. If the resistance is correct, reset the boiler and check for 120 VAC at the ignitor plug during the start cycle. If there is no voltage, replace the PCB or faulty ignitor wires.
5. Blocked or contaminated air source: Before proceeding, ensure that the vent terminal (Direct Vent installations) or the air inlet (Category IV installations) is not obstructed. In general, only direct vent installations have the potential for cross contamination (flue products entering the combustion air stream) of the combustion air source. This may be caused by leaky joints in the 3" flue pipe located inside the 5" combustion air pipe. If this is suspected, remove the front panel from the appliance, reset the boiler and allow it to go through a normal cycle. If during this cycle there is no flue odor, repair the leaky joints in the flue pipe.

## SECTION 9. Gas Valve Calibration

### 9A. Gas Valve Calibration (offset adjustment)

If poor combustion is suspected because of a strong exhaust smell, pulsation in the exhaust, or nuisance flame failure lockouts (shown as "LO" on LED), the gas valve offset pressure and exhaust CO<sub>2</sub> should be checked and adjusted, if required. A magnehelic pressure gauge (with 0.1 in. w.c. divisions) and a CO<sub>2</sub> tester are required for this adjustment.

Note: Direct vent installations may experience poor combustion that results from cross contamination of the combustion air source. Check for cross contamination before attempting offset pressure adjustment (see Section 8B-3.5).

CO<sub>2</sub> sampling may be taken at the exhaust terminal or at the sample port on the 3" exhaust located inside the front panel top cover. See Figure 28 for the location of the offset pressure port and offset adjustment.

The CO<sub>2</sub> values shown in Table 4 should be achieved when the unit is in high fire. To manually fix the unit in high fire, locate the four-pin connector on the bottom left of the control board, and jumper the middle two terminals together (see Figure 29). NOTE: For EBP (combination heat & hot water) units, when the unit is in "tank charge" mode it will stay in high fire, whether manually jumpered or not.

Note: During the prepurge cycle, the gauge will indicate several in. W.C. negative pressure.

Adjust the CO<sub>2</sub> and/or offset pressure to the values shown in Table 4.

When adjusting the offset pressure, the CO<sub>2</sub> will reduce as the offset pressure is adjusted more negative. **FINAL ADJUSTMENT OF THE OFFSET PRESSURE MUST ALWAYS RESULT IN A NEGATIVE PRESSURE UPON COMPLETION.**

## SECTION 10. Symptom Evaluations

### 10A. Delayed ignition

Possible Causes

- a. High lockup pressure (LP boilers) - occurs on start-up.
- b. Gas valve regulation problem - occurs on start-up.
- c. Incorrect gas orifice (Natural gas orifice in an LP boiler) - occurs on start up
- d. Defective burner - occurs on startup or at burner shutdown.

High lock up pressure is the most common cause of delayed ignitions on LP fueled boilers. It may result from an improper second stage regulator selection or from a faulty regulator.

Lock up can be detected by measuring the gas supply pressure to the boiler at the inlet pressure tap on the gas valve. The gas supply to the boiler must be shut off before making this connection. Use a water manometer or pressure gauge with a scale reading of at least 25 in. w. c. or 15 oz/in<sup>2</sup>. Loosen the screw in the gas valve pressure port one full turn and install a hose from the pressure gauge over the pressure port. Turn on the gas supply. The ENDURANCE boiler is designed to operate with supply pressures of 4-13 in. w. c. (2.3 - 7.5 oz/ in<sup>2</sup>). If the supply pressure exceeds 13 in. w. c. (7.5 oz/ in<sup>2</sup>) with the boiler not operating it is possible that this may be the cause of delayed ignitions and the pressure must be reset to ~ 9 in. w. c. (5.2 oz/ in<sup>2</sup>). Restart the boiler and then switch it off again. Lock up pressures must be measured when the boiler is not operating and preferably immediately after boiler shutdown. If the gas pressure again exceeds the allowable values, correct the lock up problem.

Gas valve regulation problems can also cause delayed ignitions. See “Gas valve calibration”.

Incorrect gas orifice – Check orifice size.

A defective burner can cause a delayed ignition during operation or at shutdown. If the gas supply pressure is proper the gas valve is functioning properly and the gas orifice is correct, the burner should be inspected. To inspect it, remove the blower. The burner is retained by the blower and it will drop out of the bottom of the chamber when the blower is removed. There should be no distortion or perforations in the burner other than the punched holes. Replace if indicated.

## 10B. Short Cycling

Possible causes

- a. Reduced system flow - EDP
- b. Thermostatic union (EDP) or anti-condensing valve not opening (EBP).
- c. T-T wires cross connected (jumped) – **improper installation** - EBP or EDP/EDN
- d. Leakage of flue products into the combustion air stream – Direct Vent Installations only, see Section 8B-3, Resolving Lockouts (LO), item (5).

## 10C. Noisy Operation

There are two principal sources of noisy operation:

- a. Combustion - high pitched noise - whistle or hoot.
- b. Boiling (kettling) - lower frequency noise which varies with temperature - moan.

Many times it is difficult to determine the source of the noise or if it is combustion related or boiling related. Combustion noises always have the same frequency; however, their volume may change from the time that the burner first fires to the time that it shuts off. A boiling noise is identified by rapidly raising or lowering the system water pressure while the noise is present. A change in the pitch or intensity of the noise indicates a boiling problem.

**Combustion noise** occurs at any boiler discharge temperature and is heard the loudest at the flue outlet (especially on units that are sidewall vented). There are two basic causes for the noise, rich mixture (high CO<sub>2</sub> or low O<sub>2</sub>) or cross contamination. The mixture is determined by measuring the percent O<sub>2</sub> or CO<sub>2</sub> in the flue products. O<sub>2</sub> readings lower than 4½ % or CO<sub>2</sub> readings higher than 9¼ % (natural gas) and 10.8% (LP) will often cause combustion related noise. The rich mixture could be caused by the mis-calibration of the gas valve (offset adjustment) or by the gas orifice size. To eliminate the noise; first, check the gas valve calibration. If it is correct, install a smaller gas orifice so that the O<sub>2</sub> will rise above 4½% or the CO<sub>2</sub> will drop to 8½% (natural) or 9½% (LP).

The CO<sub>2</sub> & O<sub>2</sub> readings may be influenced by cross contamination. Suspect cross contamination if the noise returns when the front panel is replaced.

**Boiling (kettling)** may occur at boiler discharge temperatures from 170°F to 210°F. The temperature at which it starts will vary from one installation to another. The primary cause of the problem is poor heat transfer on the inside of the boiler coil. This may be caused by foaming due to excessive concentration of antifreeze in the system or by scaling from the boiler water due to hardness of make up water.

Plumbing antifreezes should never be used in a boiler system. Only boiler antifreezes, with effective antifoamants, are appropriate for the ENDURANCE boilers.

Note: The concentration of appropriate antifreeze should be always be kept as low as possible to minimize its effect on heat transfer and efficiency.

The method for eliminating the boiling noise is the same regardless of the cause. However, if antifreeze in the system is suspected of being the cause, the concentration (<35%) and type should be investigated.

### Moisture

Although it is not a primary cause of lockouts, moisture in the combustion chamber may cause lockouts by weakening the flame signal to the boiler control. It should be suspected if the boiler temperature does not rise above 160°F during long periods of operation. This condition can be caused by a defective thermostat in the thermostatic union of EDN or EDP boilers (or the omission of the thermostatic union at installation) or failure of the anticondensing valve in the EBP (combi) boilers. Moisture can also get into the combustion chamber through an incorrectly pitched or incorrectly installed flue pipe (pitched back toward the boiler without a condensate trap). The flue assembly of EBP, EDN and EDP boilers installed as Direct Vent boilers should always pitch down from the boiler.

## 10D. Insufficient Hot Water (EBP only)

Possible cause:

- a. No flow restrictor (supplied with unit - field installed)
- b. Water flow switch failure
- c. Mixing valve setting or failure
- d. Domestic hot water (DHW) heat exchanger contamination

The most common cause for insufficient hot water complaints results from failure to install a flow restrictor. The absence of a flow restrictor allows water to pass through the heat exchanger at a greater rate than the boiler output is capable of heating to the desired temperature.

Failure of the water flow switch to operate during a hot water draw prevents boiler water from



flowing through the DHW heat exchanger and therefore the DHW will not be heated.

To test the switch, place a **temporary** jumper across the back of the connector on the PCB (see wiring diagrams for connector location). If the internal pump operates and there is DHW generated then the water flow switch is faulty and must be replaced.

Note: Switch orientation is critical for proper switch operation. The identification plate on the switch must face up and the arrow on the plate must point in the direction of flow.

Failure of the mixing valve will allow cold water to be mixed with the hot water from the DHW heat exchanger during a DHW draw regardless of the setting of the mixing valve or the temperature of the water leaving the DHW heat exchanger. The failure can be detected by observing the temperature of the three pipes connected to the mixing valve. If the “mix” temperature is luke warm or cool and the “hot” temperature is hot and the “cold” temperature is cold then the mixing valve is either faulty or incorrectly adjusted and must be replaced or adjusted.

DHW heat exchanger scaling may occur in some areas of the country where there are high concentrations of minerals in the water. These minerals may cause fouling of the DHW heat exchanger over an extended period of time (lime build up). Other minerals, which react more quickly in well

systems (mostly magnesium), cause slime on the inside of the heat exchanger and prevent adequate heat transfer. These minerals must be filtered out by a special incoming water filter or by the addition of an inhibitor to protect the coil and provide acceptable water quality. Minerals may be removed when necessary by flushing the coil with a cleaner such as “Unlime®” or “Sizzle®”.

## 10E. High Gas Consumption

Boilers operating with an improper air/fuel ratio are very inefficient and consequently, have very high gas consumption. Because efficiency is high when the CO<sub>2</sub> is high, boilers operating with low CO<sub>2</sub> (especially LP boilers) consume more gas. Adjust the CO<sub>2</sub> or O<sub>2</sub> for optimum efficiency. If no combustion analyzing equipment (CO<sub>2</sub> or O<sub>2</sub>) is available then a proper adjustment of the air/fuel ratio (CO<sub>2</sub>) can not be accomplished. However, by briefly sniffing the flue gases it is possible to determine if the CO<sub>2</sub> or O<sub>2</sub> is within the proper range. There is no significant flue gas odor when combustion is proper. A strong piercing smell indicates poor combustion and generally a lean mixture (low CO<sub>2</sub>). Check gas valve calibration (offset adjustment) and adjust if indicated. Do not attempt to correct combustion by reorificing without an O<sub>2</sub> or CO<sub>2</sub> kit.

## SECTION 11. Parts Identification

Description	Part Number
1. PAN, COMBUSTION CHAMBER TOP	2400-502
2. PAN, COMBUSTION CHAMBER BOTTOM	2400-504
3. INSULATION, COIL COVER	2400-506
4. INSULATION, BOILER COIL	2400-508
5. COIL, BOILER, EBP/EDP/EDN 110 (ASSY.)	2400-510
6. COIL, BOILER, EBP/EDP/EDN 175 (ASSY.)	2400-512
7. GASKET, BURNER	2400-514
8. BURNER, EBP/EDP/EDN 110 (GASKETS INCLUDED)	2400-516
9. BURNER, EBP/EDP/EDN 175 (GASKETS INCLUDED)	2400-518
10. TRANSFER TANK	2400-520
11. BOILER DRAIN (BEHIND PANEL-EBP)	2400-522
12. BLOWER, COMBUSTION AIR (GASKETS INCLUDED)	2400-524
13. IGNITOR/FLAME SENSOR (GASKET INCLUDED)	2400-526
14. GASKET, IGNITOR/FLAME SENSOR	2400-528
15. COIN VENT	1-592
16. COMBUSTION AIR INLET, ADJUSTABLE, KIT	2400-142
17. VALVE, ANTI CONDENSING, REPAIR KIT	2400-538

Description	Part Number
18. GASKET, BLOWER	2400-540
19. WATER FLOW SWITCH	2400-542
20. BOILER CONTROL (BEHIND PANEL) (EBP)	2400-546
21. GAS VALVE, HONEYWELL, NEG. REG. PRESSURE	2400-548
22. SAFETY LIMIT, 230 °F	2400-550
23. SENSOR, TANK ( EBP ONLY )	2400-552
24. SENSOR, BOILER FLOW	2400-554
25. SENSOR, BOILER RETURN	2400-556
26. THERMOSTATIC UNION EDP (NOT SHOWN)	2400-030
27. GAS SHUTOFF VALVE	2400-560
28. PUMP, EBP/EDP 110	2400-592
29. PUMP, EBP/EDP 175	2400-386
30. GASKETS, PUMP FLANGE	2400-566
31. RESET SWITCH	2400-568
32. HEAT EXCHANGER, DOM. HOT WATER	2400-570
33. GASKETS, DHW HEAT EXCHANGER	2400-572
34. BUTTON, ON/OFF (PART OF 2400-546)	-
35. BUTTON, TEMP/MESSAGE (PART OF 2400-546)	-
36. GAUGE, PRESSURE (NOT SHOWN)	2400-574
37. PRESSURE RELIEF VALVE (30 PSIG, NOT SHOWN)	2400-112
38. BOILER CONTROL (BEHIND PANEL) (EDP/EDN)	2400-558
39. PUMP, EDN 110	2400-388
40. PUMP, EDN 175	2400-388
41. THERMOSTATIC UNION EDN (NOT SHOWN)	47-026
42. TRANSFORMER (NOT SHOWN)	2400-562

Model EDP/EDN

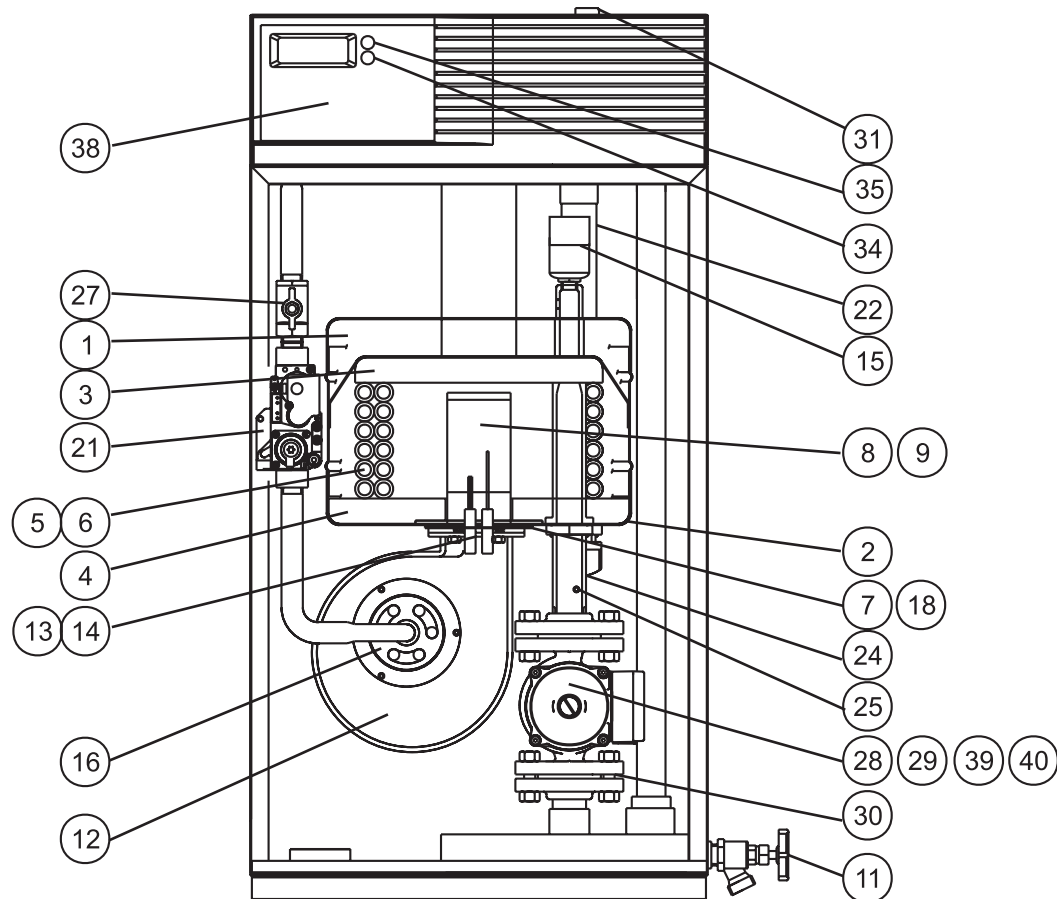

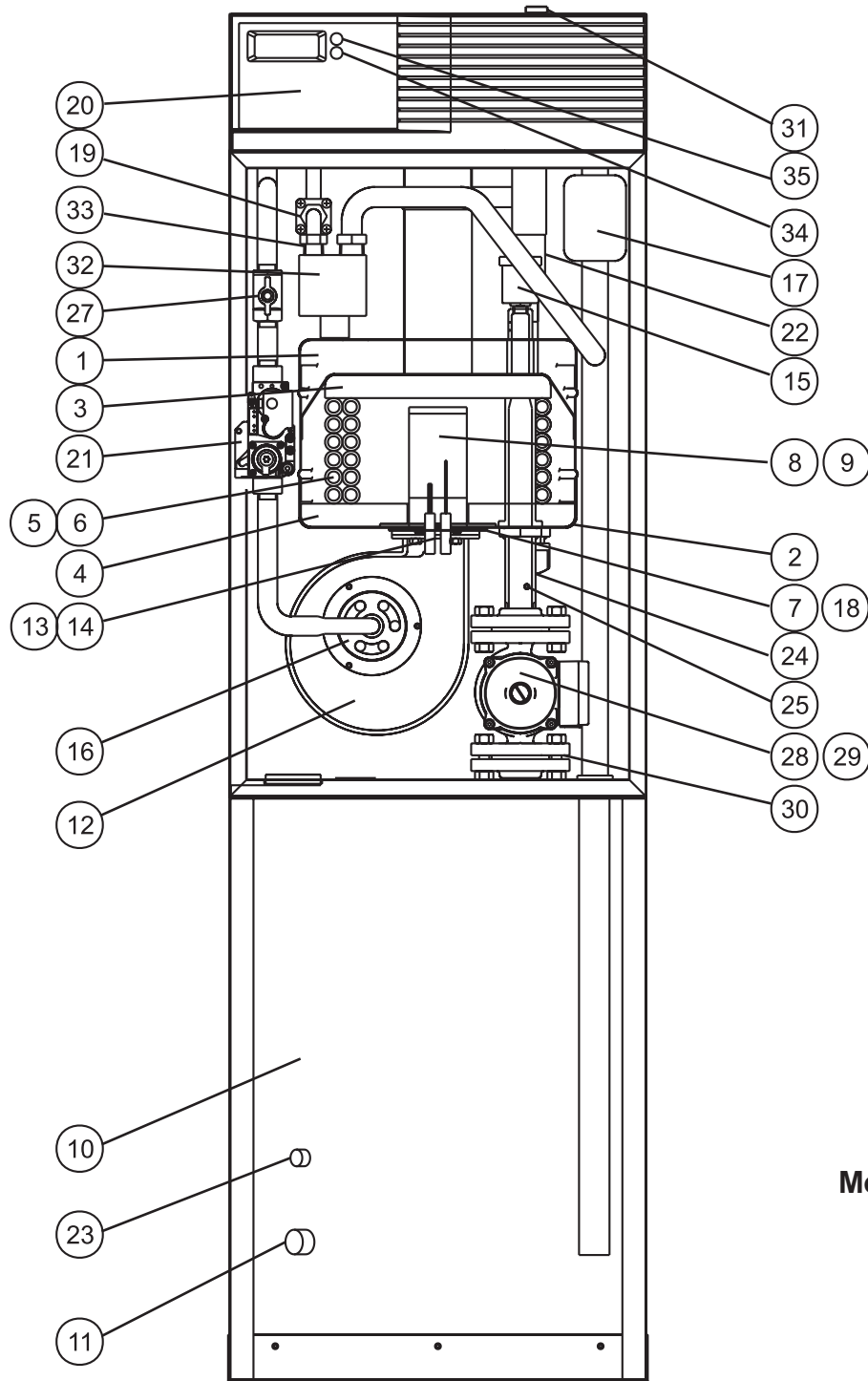

**Model EBP**

Boiler Drain



As an Energy Star® Partner, Laars has determined that this product meets the Energy Star® guidelines for energy efficiency.



---

P.O. Box 310  
Lynnfield, MA 01940  
Phone: 781-961-1660  
Fax: 781-334-2541